



ENSTO

Solutions for Overhead Line Networks

Accessories for up to 45 kV



Better life.
With electricity.

Reliable and installer-friendly products that are designed to last for decades even in the most challenging weather conditions

[ensto.com](https://www.ensto.com)



Content

Ensto – Electrical Solution Provider	4
Ensto Pro Training Academy.	6
Ensto Solutions for Low Voltage Systems	8
Uninsulated Messenger Wire System (AMKA)	11
Four Core System.	12
Insulated Messenger Wire System (IMWS).	13
LVAC Power Quality.	14
Pole Fuse Switch Disconnecter	15
Products	16
Lamp Post Fixtures	48
Ensto Solutions for Medium Voltage Systems.	50
Covered Conductor Solution	51
Full Covered Conductor Solution	52
Bare Conductor System	54
Universal Cable System.	55
Ensto Crossarms and Pole Accessories	
for MV Systems	56
Network Automation	57
Ensto Surge Arresters	58
Products	59
SZ 24 Disconnecter	72
Tools	86



Making life better with electricity.

Sustainable.

We offer smart and reliable electrical solutions and expertise for electricity distribution system operators and help them to succeed and create a more sustainable tomorrow.

For over 60 years, Ensto, a growth-oriented and international family business, has been dedicated to electricity with a long-term and human-centric approach. Currently Ensto has a total of 850 employees in 17 countries in Europe and Asia.

Ensto offers innovative and reliable, long life-cycle products and solutions for overhead lines, underground cables, power quality, and network automation.

We are the technology leader in full covered conductor solution (FCCS) and the trusted technology expert in cyber-secured Network Automation. We are also a leading technology provider for MV cold shrink.

Our proven technologies and unique customer support ensure reliable electricity distribution. We are bound by our common purpose: making life better with electricity. Sustainably.

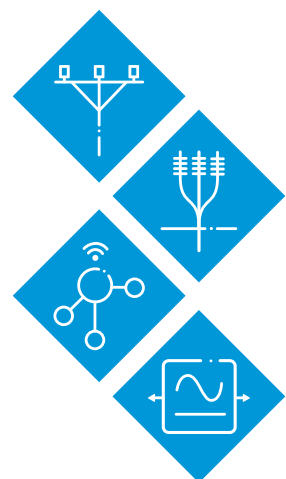



Well Functioning Solutions

Ensto's solutions play a key role in building reliable, low-loss electricity distribution networks with disturbance-free service. High-quality products guarantee lower total costs for creating robust distribution networks. We have thorough experience and knowledge of distribution networks in even the most demanding conditions: cold, hot, and stormy surroundings all over the world. Our products are developed in close cooperation with our customers. They are designed for a long service life, minimal need for maintenance, and a low life-cycle impact on the environment.

Tested to Meet Your Expectations

Ensto has fully equipped and calibrated testing laboratories in-house; even an accredited one in our headquarters in

Finland. We test our products to ensure meeting the toughest national and international standards – in fact, beyond standard requirements. We work with many international test laboratories and use well-known external laboratories for certification testing.

Answers Close to You

Ensto has local sales personnel in 17 countries, allowing us to serve and support our customers flexibly in their own language, thanks to a strong local presence. In addition, we sell throughout the world to more than 100 countries.

Unique Training

Ensto's extensive training program Ensto Pro provides continuing support and comprehensive training for our customers. The benefits of this training include time, cost, and energy savings and fewer

installation errors. Moreover, we receive reliable input on the solutions the customer truly needs. All Ensto Pro training sessions are customized according to customer needs.

Focus on Energy-Efficiency

Ensto is committed to building sustainable energy infrastructure with energy-efficient solutions.

Higher-quality power and lower distribution losses are key to energy efficiency. Sustainability and efficiency are also achieved via recyclable materials, local expertise, and in-house manufacturing. Ensto's solutions for network power quality improve efficiency in electricity distribution and the quality of electricity. They save your time, money, and energy.



Ensto Pro

TRAINING ACADEMY



Ensto Pro is our technical training concept targeted to customers, partners and own personnel. The aim is **to support sales and create loyal customer relations** by sharing knowledge.

As our customer you gain these benefits from Ensto Pro training

- › Time, cost, and energy savings
- › Fewer installation errors
- › Confidence and motivation
- › The opportunity to have an influence
- › New perspectives.

Better life.
With electricity.

Ensto Pro Training Academy

Assuring Know-How and Reliable Installations

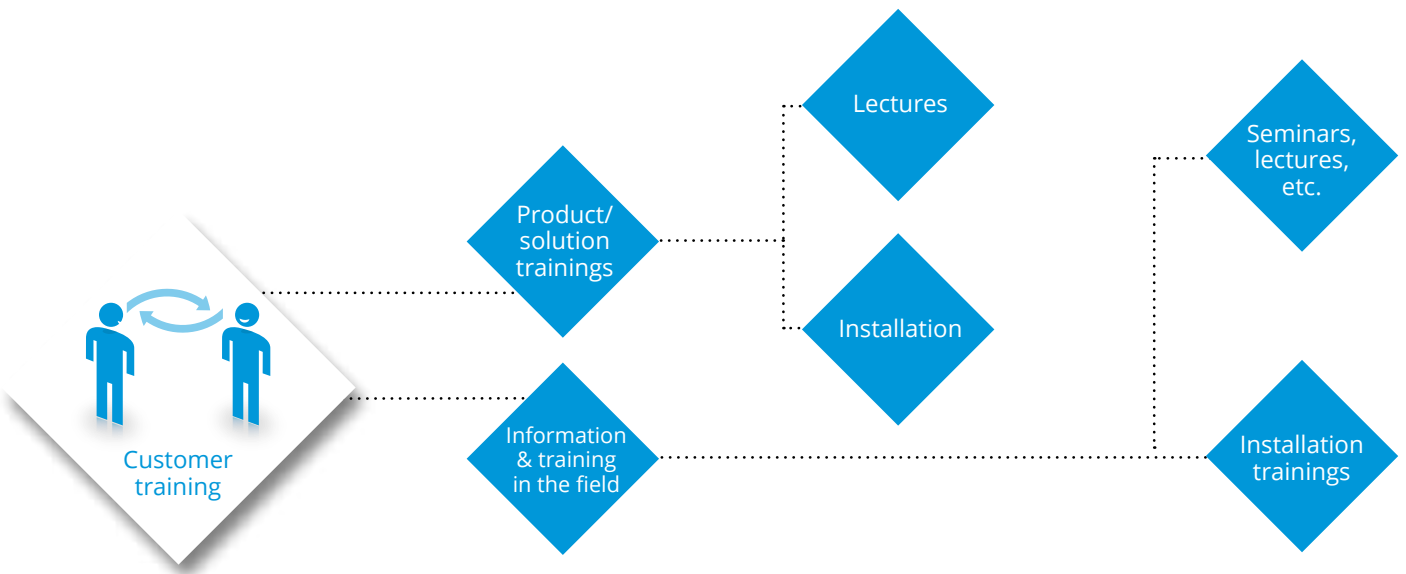

Ensto Pro – and You Know!

Our Knowledge at Your Disposal

Customer training sessions are a vital part of our operations. We offer more than products: a complete package with reliable solutions, professional service, and customized support. They allow us to create profitable, long-term relationship of true collaboration.

Ensto has offered technical training to customers for decades. We want to share with you our 60-year experience in electricity network building and making the most of our products in varied, demanding circumstances. At the same time, we wish to learn from your experiences and truly understand your requirements, thereby becoming able to develop our products to best meet those precise needs.

Unique and Customized Training

Training helps to create true connection between us and you, the customer. We get realtime information on what you want, while you can learn about, for instance, products, installation methods, and distribution network design.

Our Ensto Pro service is unique:

- We give local service in the local language.
- We customize all Ensto Pro trainings.
- We are easy-going professionals.
- We enforce our credibility with a consistent and appealing appearance and presentation.
- We emphasize two-way learning.
- We keep our promises.

Variety of Training Types

Our customer training ranges from small installation sessions to large lecture-type events. Also, we are ready to teach about a host of topics as customer needs and wishes dictate.

Often, we arrange, or are involved in, sessions attended by professionals from various institutions, such as cable manufacturers and energy-market authorities. By offering all the necessary information in one session, we save time and energy. We care about your success.





LOW



Reliable Solutions for Low Voltage Systems

Ensto has been developing solutions for overhead lines since the early 1960s.

With solid engineering support, enable creating a reliable, low-loss distribution network with a long service life. Our focus is on high-quality and professional service.



Properties and Typical Values of LV ABC (Aerial Bundle Cable)



Properties and Typical Values of LV ABC (Aerial Bundle Cable) Overhead Line Systems Realized with Ensto Fittings



Character/Criteria	Four core system	Insulated neutral messenger wire	Uninsulated neutral messenger wire
Description	Four equal aluminium alloy conductors including phase – and neutral conductors. The cable can also have separate conductors for street lighting.	Insulated aluminium phase conductors. Insulated aluminium alloy messenger wire, which is also the neutral conductor. The cable can also have separate conductors for street lighting.	Insulated aluminium phase conductors. Bare aluminium alloy messenger wire, which is also the neutral conductor. The cable can also have separate conductors for street lighting.
Minimum breaking loads for the conductor	4x35 mm ² = 22.4 kN 4x50 mm ² = 33.2 kN 4x70 mm ² = 45.3 kN 4x95 mm ² = 60.8 kN 4x120 mm ² = 75.2 kN	3x35 mm ² + 54.6 mm ² = 16.0 kN 3x70 mm ² + 54.6 mm ² = 16.0 kN 3x120 mm ² + 70.0 mm ² = 17.7 kN	3x35 mm ² + 50 mm ² = 14.7 kN 3x70 mm ² + 95 mm ² = 27.9 kN 3x120 mm ² + 95 mm ² = 27.9 kN
Sharing of mechanical load	Mechanical load applied in all conductors.	Messenger wire carries all mechanical load.	Messenger wire carries all mechanical load.
Tensile strength of wires of conductor (N/mm ²)	All conductors 160 N/mm ²	Neutral 300 N/mm ² Phases 120 N/mm ²	Neutral 300 N/mm ² Phases 120 N/mm ²
Risk of neutral breaking under unexpected loads like falling trees etc.	The neutral is unlikely to break alone, if the installation is made properly. High mechanical strength.	The neutral may break alone, if not provided with weak links. Risk to personnel and apparatus due to risen phase voltage and high potential in neutral, if the earthing is not made properly.	The neutral is reinforced, but it may break alone. Risk to personnel and apparatus due to risen phase voltage and high potential in neutral, if the earthing is not made properly.
Live line work	No special requirements.	No special requirements.	No special requirements. Uninsulated neutral may have touch voltage in poor earthing conditions. Proper earthing is essential.
Connectors	Same connector can be used for all cores.	Sometimes different connectors for phases and neutral.	Sometimes different connectors for phases and neutral.
Risk of corrosion in the neutral	Reduced risk.	Reduced risk.	Potential risk in extreme climatic conditions.
Installation methods	No special tools or methods. Suspension clamps with incorporated pulleys available.	No special tools or methods. Pulleys are needed.	No special tools or methods. Pulleys are needed. Economical fittings.





Uninsulated Messenger Wire System (AMKA)



Ensto has developed solutions and integrated product packages for various Low Voltage ABC (Aerial Bundled Cable) systems since the early 1960's.

The solutions are designed to meet the international and local standards and take into account the special requirements of the urban, rural and forested areas, density of population, climatic conditions, available investments etc.

The AMKA System is a reliable, safe and easy way to build a low voltage overhead line system. Because of the small amount of components and short poles it is easy to build and preferred by many professionals. AMKA is used e.g. in Finland, Estonia, Hungary,

Russia and Turkey. Ensto offers a complete product package developed especially for the AMKA System.

The products are easy to install and have been proven to last for decades even in the severe Northern climatic conditions. Ensto solutions for Uninsulated

► Solutions for Messenger Wire System are introduced since page 24.



Four Core System



Since the 1970's the Four Core System has been adapted in many Central and North European countries e.g. in Austria, Germany, Ireland, United Kingdom, Poland, Hungary, Russia and Scandinavia.

The four equal insulated conductors, that share the tensile load equally, have size range of 16 to 185 mm². They are made of aluminium with a relatively high tensile strength. Therefore, the breaking load of the cable is relatively high, too. Insulation of the cores is typically made of XLPE or PE. The cable can be supplied

with one or two insulated conductors for street lighting. Some countries use PE and others XLPE insulation with respective continuous operating temperatures of 65°C or 75°C.

Ensto's Four Core Solution includes a complete package of accessories for the Four Core System. Ensto products ensure reliable and long lasting solu-

tions suitable for the most demanding circumstances.

➤ Read more about the Ensto solutions for four core systems since page 19.

Insulated Messenger Wire System (IMWS)



An insulated messenger wire cable consists of one to five black, weather resistant, high density or cross-linked, polyethylene insulated conductors twisted around an insulated aluminium alloy messenger (typical tensile strength 300 N/mm²).

The Ensto portfolio for Insulated Messenger Wire System, Ensto IMWS, includes connectors, tension and suspension clamps, pole fuse switches and various pole support and earthing accessories. Our competitiveness is based on long-term customer relations resulting in safe systems for the most demanding circumstances using durable

products. We take care of our customers and offer the best solutions on an individual basis.

The messenger, which is also the neutral conductor, takes all the mechanical stress. The cross section of the phase conductors can vary from 16 to 185 mm² to meet the load current, maximum acceptable voltage drop and short circuit

current of the network; the size of the messenger varies from 25 to 95 mm², depending on mechanical and electrical conditions.

➤ Ensto solutions for Insulated Messenger Wire System are covered on pages 22.

LVAC Power Quality

Improving Power Quality Line by Line All the Time



Ensto's LVAC Power Quality solutions are maximizing the capacity, safety, and lifetime of existing low voltage grids with cost-effective and fast ways.

Intelligent Devices for High Electricity Quality

The devices we develop and manufacture represent the latest innovations, and their purpose is to improve the quality of electricity at the remote end of a low voltage distribution network, so that electricity of always equally high quality can be delivered throughout the network.

Voltage Booster is the choice when having problems with lowered voltage levels. Even in the most difficult situations, it boosts the voltage up to 20%.

Voltage Controller is the choice if eg. overvoltage problems caused by renewable energy production, exist in low voltage network. This small device can easily repair either lowered or overvoltage problems.

Phase Balancer increases the safety! The device increases short circuit currents, which enables faster response of the protective devices in the fault situations. It also corrects asymmetric load problems and decreases harmonic distortion in low voltage networks.

Why focus on Quality of Electricity?

Quality requirements are set for electricity distribution in, for example, the EN50160 standard. According to this standard, the line voltage is to remain within $\pm 10\%$ of the nominal value. Ensto's LVAC Power Quality Solutions help you avoid extra costs caused by falling outside this range. Our cloud-based platform Ensto Utility Manager is an important part of the solution and helps in preventing, controlling and locating any possible defects in electricity distribution by analyzing continuous measurement and status information.

New Design for Ensto Pole Fuse Switch Disconnecter



The originally proven design of Ensto pole fuse switches has been further improved. Now the new fuse switch family can be operated from the ground by using the operating stick and separate terminal covers make the installing easier and safer.

The SZ160 family will replace the existing pole fuse switch disconnecter models SZ50-SZ150, which have been sold and installed hundreds of thousands pieces all over the world. Products are designed in Finland and they last from father to son – and even longer.

The products are used for protecting stranded overhead cables and underground cables in low voltage networks.

Main benefits for pole fuse switches

- Safe and easy to install
- Separate terminal covers
- Operating stick
- Suitable for extreme conditions
- Type tested
- Laser marking
- Robust locking mechanism



Products



Connectors

Ensto offers a revolutionary family of connectors. Ensto connectors have been used around the world since the mid 1960's.

Our connectors are designed to resist corrosion and bimetallic electrochemical reactions and to endure varying mechanical tensions and other forces detrimental to the connection.

Our portfolio includes:

- Weather- and waterproof insulation piercing connectors
- Parallel groove connectors for both Al/Al and Al/Cu conductors
- Insulating covers for the connectors
- Busbar connectors, cable lugs, cable joints

➤ Read more since page 25.



Copper Bars

Copper bars are used together with busbar connectors to connect Cu- or Al- conductors to high- or low-voltage transformer bushings. It is important to brush and grease the Al-connection.

Flat copper bars are tin-plated to reduce corrosion between aluminium and copper.

➤ Read more on page 35.



Bird Protectors

Environmental aspects are increasingly important when building an electricity network today. Ensto is working together with electricity utilities and environmental experts to find ways to protect wildlife from electricity distribution network.

➤ Read more about Bird protectors for low voltage system on page 36 and for medium voltage system since page 69.



Cable Lugs, Earthing Connectors and Earthing Bars



The cable lugs are used for terminating conductors of 1 kV cables. Because of the shear head bolt construction, no crimping tools are needed.

The lugs are water tight and suitable for solid and stranded, sector shaped and circular conductors.

Earthing connectors are used for the connection of earthings in pole transformer stations. The earthing conductors can be connected to the bar by using KG connectors.



➤ Read more on page 36.

Pole Fuse Switch Disconnectors

Pole fuse switch disconnectors are used for protecting low-voltage networks. They combine the functions of a fuse, a switch and a disconnector. Pole fuse switches are easy to use as they can be operated from the ground by using a rod.

They are also reliable and work for decades even in the most severe conditions. Their reliability and safety has been proved in numerous tests in accordance with IEC and national standards. We manufacture 160 A and 400 A pole fuse switches.

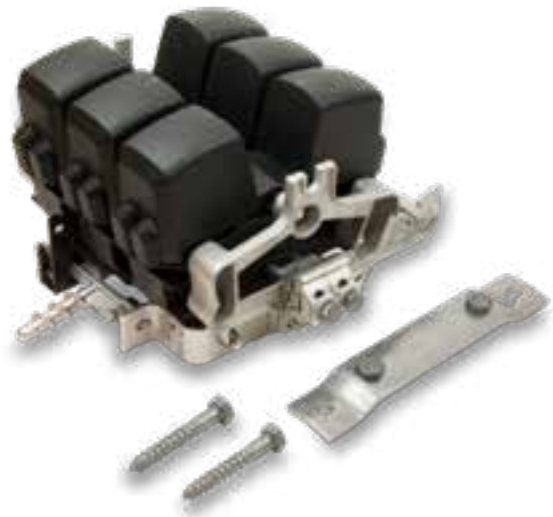

➤ Read more on pages 38-39.

Lamp Post Fixtures

Lamp post fixtures are used for connecting and branching aluminium and copper cables in lamp posts and cable cabinets. The fixtures are insulated.

➤ Read more on page 48.



Fixing Materials for Pole and Wall Mount

AB cables have usually a single layer of insulation only. They are not intended to be installed directly to the supporting surface. The wall mount fittings and the distance clips make it possible to install cables on various surfaces horizontally and vertically.

➤ Read more on pages 42-43.



Suspension Hooks

AB cables are suspended on wooden, concrete or steel poles and walls. Every support requires its own tensioning device. The Ensto hook program has a solution for all needs and tensions required. The installation is easy and quick and no special tools are needed.

➤ Read more on pages 44-45.



Stay Wire Accessories and Pole Base Reinforcers

Ensto offers supporting stay wire sets, pole base reinforcers, and pole hats. We have a variety of standardized sets available, which makes the material handling easy and speeds up the line erection process. Ensto's pole base reinforcers increase the life time of the poles.

➤ Read more on pages 46-47.



Tools

Ensto's tool selection includes products that are especially designed to fit the needs of network installers. Together with our customers we have developed many tools to facilitate the installation work. When installers use tools that fit and are designed for their work, a reliable installation can be made safely. Furthermore, a well-made installation has great impact on the service life and reliability of the network.

➤ Read more on pages 87-89.



Low Voltage Overhead Line Solutions Ensto Four Core System



Tension Clamps

Tension clamp SO243

The SO243 is a tension clamp for four core service connections – made from weather durable and mechanically reliable polymeric plastic. The light weight design of SO243 provides extremely easy and quick anchoring of LV overhead cables – either to poles or walls by means of standard hooks. No tools are required during the installation.

Product code	GTIN	Conductor size mm ²	Conductor diameter mm	SMFL kN	Weight (kg)	Pack. /pcs
SO243	6418677437977	2-4x(6-25)	5.3-9.1	2	0.07	50

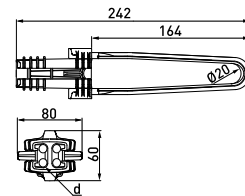

Tension clamp SO234S

For the termination of 4-core overhead cables. The tension clamp is equipped with shearhead nuts.

Tension clamp SO234S

For the termination of 4-core overhead cables. The tension clamp is equipped with shearhead nuts.

Product code	GTIN	Conductor size mm ²	Conductor diameter mm	Tightening torque Nm	SMFL kN	Weight (kg)	Pack. /pcs
SO234S	6418677442339	4x(50-120)	10.8-16.7	44	4x50mm ² 27 kN 4x70mm ² 37 kN 4x95mm ² 37 kN 4x120mm ² 37 kN	1.3	10

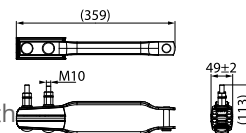

Tension clamp SO274S

Tension clamp for the termination of 4 core overhead cables. The tension clamp is equipped with shearhead nuts.

Product code	GTIN	Conductor size mm ²	Conductor diameter mm	Tightening torque Nm	SMFL kN	Weight (kg)	Pack. /pcs
SO274S	6418677446696	4x(25-50)	7-10.2	47	4x25mm ² 13 kN 4x35mm ² 17.8 kN 4x50mm ² 25 kN	1	10

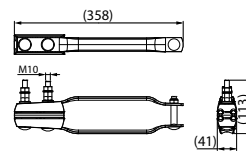

Tension clamp SO275S

Tension clamp for the termination of 4 core overhead cables. The tension clamp is equipped with shear head nuts.

Product code	GTIN	Conductor size mm ²	Conductor diameter mm	Tightening torque Nm	SMFL kN	Weight (kg)	Pack. /pcs
SO275S	6418677446719	4x(50-70)	11.6-13.2	47	4x50 mm ² 25 kN 4x70 mm ² 36 kN	1.22	10

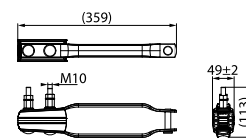

Tension clamp SO276S

Tension clamp for the termination of 4 core overhead cables. The tension clamp is equipped with shear head nuts.

Product code	GTIN	Conductor size mm ²	Conductor diameter mm	Tightening torque Nm	SMFL kN	Weight (kg)	Pack. /pcs
SO276S	6438100312008	4x(70-120)	12.7-17.6	47	50 kN	2.355	10

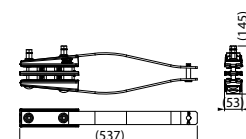

Tension clamps SO157.1S and SO158.1S

SO157.1S is used for the anchoring of a 2-core overhead cable to poles or walls by means of standard hooks. The tension clamp is equipped with shearhead nut. SO158.1S is used for the tensioning of a 4-core overhead cable to poles or walls by means of standard hooks. The tension clamp is equipped with shearhead nut.

Product code	GTIN	Conductor size mm ²	Conductor diameter mm	Tightening torque Nm	SMFL kN	Weight (kg)	Pack. /pcs
SO157.1S	6438100304652	2x(16-35)	7.0-10.2	22 Nm	6 kN (2x16 mm ² 2,5 kN, 2x35 mm ² 5,6 kN)	0.087 kg	50
SO158.1S	6438100304669	4x(16-35)	7.0-10.2	22 Nm	8,5 kN (4x16 mm ² 5,0 kN, 4x35 mm ² 8,5 kN)	0.103 kg	50

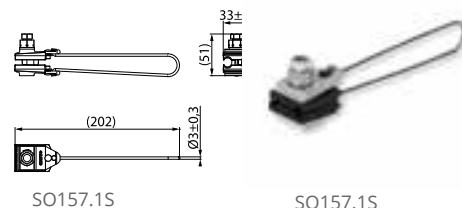

Tension clamp SO80S

Description Tension clamp for the anchoring of 4-core overhead cables to poles or walls by standard hooks. Tension clamp is equipped with a spring and shear head screw to make the installation easier.

Product code	GTIN	Conductor size mm ²	Conductor diameter mm	Tightening torque Nm	SMFL kN	Weight (kg)	Pack. /pcs
SO80S	6438100304546	4x(16-35)	7.0-10.2	22	4x16 mm ² 8 kN/ 4x25 mm ² 10 kN/ 4x35 mm ² 12 kN	0.23	25

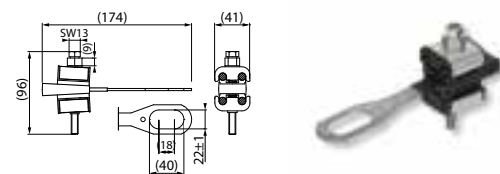

Tension clamp SO80.235S

Description Tension clamp for the anchoring of 2-core overhead cables to poles or walls by standard hooks. Tension clamp is equipped with a spring to make the installation easier.

Product code	GTIN	Conductor size mm ²	Conductor diameter mm	Tightening torque Nm	SMFL kN	Weight (kg)	Pack. /pcs
SO80.235S	6438100307646	2x(16-35)	7.0-10.2	22 Nm	4x25mm ² 14.5 kN / 4x35mm ² 20 kN	0.20	50

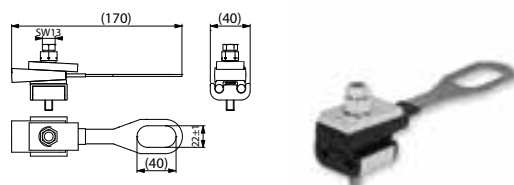

Tension clamp SO118.425S

For the termination of 4-core LV ABC cable with hook fixing. Clamp is equipped with shear-head nuts. The clamps have strong springs which keep the clamp in an open position during the installation of conductors. The clamping action functions through wedges. The body is made of weather resistant aluminium alloy and the plastic parts of special fibreglass reinforced plastic.

Product code	GTIN	Conductor size mm ²	Conductor diameter mm	Tightening torque Nm	SMFL kN	Weight (kg)	Pack. /pcs
SO118.425S	6418677442261	4x(25-35)	8.4-9.2	44	4x25mm ² 14.5 kN / 4x35mm ² 20 kN	0.465	25

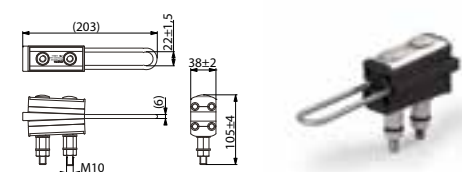

Tension clamps SO118.1201S

For the termination of 4-core LV ABC cable with hook fixing. The clamps have strong springs which keep the clamp in an open position during the installation of conductors. The clamping action functions through wedges. The body is made of weather resistant aluminium alloy and the plastic parts of special fibreglass reinforced plastic.

Product code	GTIN	Conductor size mm ²	Conductor diameter mm	Tightening torque Nm	SMFL kN	Weight (kg)	Pack. /pcs
SO118.1201S	6418677442247	4x(50-120)	10.8-16.7	44	4x50 mm ² - 23kN / 4x70 mm ² - 33kN / 4x95 mm ² - 35kN / 4x120 mm ² - 35kN	1.2	10



Tension clamp SO118.1202S

For the termination of 4-core LV ABC cable with hook or universal fixing. The clamps have strong springs which keep the clamp in an open position during the installation of conductors. The clamping action functions through wedges. The body is made of weather resistant aluminium alloy and the plastic parts of special fibreglass reinforced plastic.

Product code	GTIN	Conductor size mm ²	Conductor diameter mm	Tightening torque Nm	SMFL kN	Weight (kg)	Pack. /pcs
SO118.1202S	6418677442254	4x(50-120)	10.8-16.7	44	4x50 mm ² 27 kN/ 4x95-120 mm ² 35 kN	1.38	10

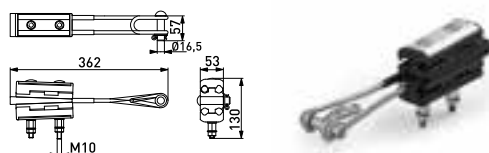

Suspension Clamps

Suspension clamp SO99

Used for the installation and suspension of cables from poles in straight lines and at angles of up to 90° with 4x25 mm² and 4x50 mm² cables or up to 60° with 4x95 mm² cables.

Product code	GTIN	Conductor size mm ²	Conductor diameter mm	Tightening torque Nm	SMFL kN	Weight (kg)	Pack./ pcs
SO99	6418677405181	4x(25-95)	18-39	12	18	0.825	10

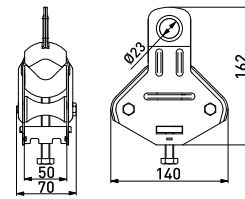

Extension roller ST26.99

This additional roller set fits easily onto the SO99 clamp. It is used when angles exceed 30 degrees.

Product code	GTIN	Weight (kg)	Pack. / pcs
ST26.99	6418677405501	2.3	10

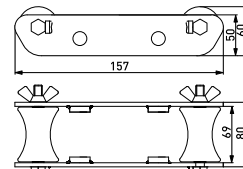

Suspension clamp SO270

For the installation and suspension of 4-core ABC cables from poles with standard hook attachment. For straight lines and depending on cross section angles up to 15/30 degrees. Structure itself provide installation without any tools. Clamp including composite parts is protected form wearing in hook attachment point.

Product code	GTIN	Conductor size mm ²	Conductor diameter mm	Tightening torque Nm	SMFL kN	Weight (kg)	Pack. / pcs
SO270	6418677441875	2x(25-35), 4x(16-120)	12-42	5	7	0.150	25

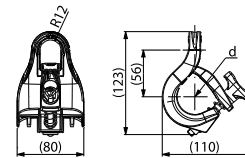

Suspension clamps SO130 and SO130.02

SO130 is used for the installation and suspension of LV ABC cables to poles with standard hook attachment. For straight lines and angles up to 30° 4x(25-120 mm²) and 60° 4x(25-50 mm²). Thanks to the integrated construction, no extra parts are needed for the installation. The body is made of corrosion proof aluminium and the inserts of weather resistant plastic. SO130.02 is equipped with a wing nut.

Product code	GTIN	Conductor size mm ²	Conductor diameter mm	Tightening torque Nm	SMFL kN	Weight (kg)	Pack. / pcs
SO130	6418677404306	2-4x(16-120)	12-42	10	18	0.294	25
SO130.02	6418677419201	2-4x(16-120)	12-42	10	18	0.31	25

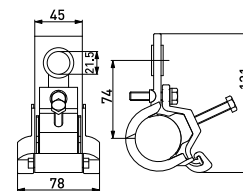

SO130

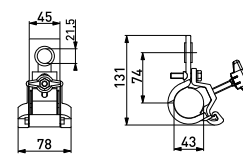

SO130.02



Suspension clamps SO136 and SO136.02

For the installation and suspension of 4-core LV ABC cables to poles with standard hook attachment. For straight lines and angles up to 90°. No extra parts are needed for the installation. SO136.02 is equipped with a wing nut.

Product code	GTIN	Conductor size mm ²	Conductor diameter mm	Tightening torque Nm	SMFL kN	Weight (kg)	Pack. / pcs
SO136	6418677404368	2-4x(25-120)	12-42	10	40	0.730	10
SO136.02	6418677419225	2-4x(25-120)	12-42	10	40	0.745	10

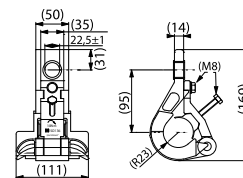

SO136
SO136.02

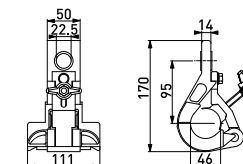

Insulated Messenger Wire system

Tension clamps SO250

SO250- series consists of clamps for different messenger cross sections suitable for various climatic conditions. The clamps are easy to install without tools and available for both bracket and hook installation to wooden, concrete or steel poles. Clamps are supplied with or without the bracket.

Product code	GTIN	Bracket	Messenger mm ²	Messenger dia. mm	SMFL kN	Weight (kg)	Pack. /pcs
SO250	6418677418679	with bracket	50-70	11-14	15	0.58	10
SO250.01	6418677418617	without bracket	50-70	11-14	15	0.47	25
SO251	6418677418693	with bracket	95	15-15.5	15	0.58	10
SO251.01	6418677418709	without bracket	95	15-15.5	15	0.47	25
SO252	6418677418716	with bracket	25-35	8.5-11	12	0.58	10
SO252.01	6418677418723	without bracket	25-35	8.5-11	12	0.47	25
Only bracket							
SO253	6418677418907				22	0.11	25

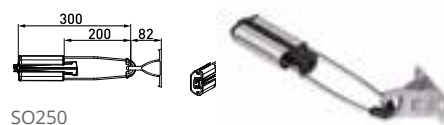

SO250

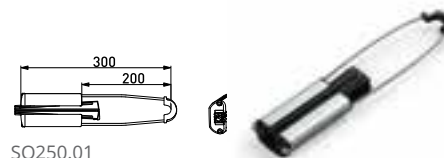

SO250.01

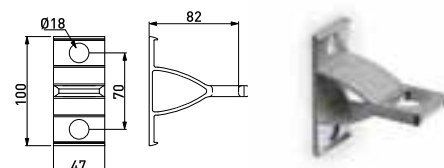

SO253

Suspension clamp SO260

For suspending of LV ABC cables in an insulated messenger wire system (IMWS). Suitable for every climatic conditions. Bracket pre installed.

Product code	GTIN	Bracket	Messenger mm ²	Messenger dia. mm	SMFL kN	Weight (kg)	Pack. /pcs
SO260	6418677418914	with bracket	25-95	8.5-15.5	12	0.37	20
SO260.1	6418677419058	without bracket	25-95	8.5-15.5	12	0.16	50
Only bracket							
SO260.2	6418677419065				15.5	0.21	50

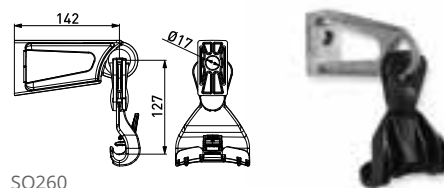

SO260

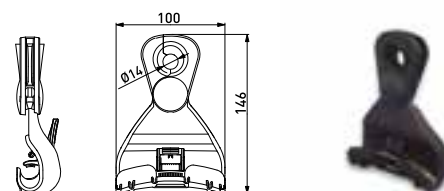

SO260.01

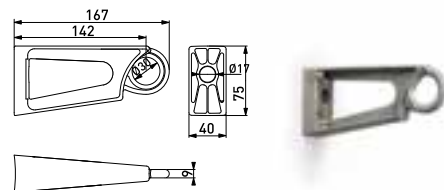

SO260.2



Suspension clamp SO265.1

For suspending of LV ABC cables in an insulated messenger wire system (IMWS) with standard hook installation. Easy to install without tools. The messenger is placed to the groove and locked with the locking part. Clamp equipped with wear protection plate.

Product code	GTIN	Messenger mm ²	Messenger dia. mm	SMFL kN	Weight (kg)	Pack. /pcs
SO265.1	6418677419553	16-95	7.5-15.5	12	0.1	20

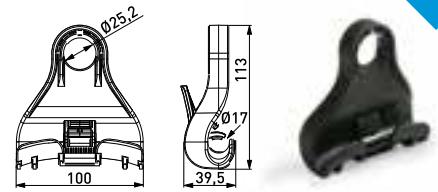

Suspension clamp SO69.95

The suspension clamp is used for the suspension of the insulated messenger in straight lines and at angles up to 90°.

Product code	GTIN	Messenger mm ²	Messenger dia. mm	SMFL kN	Weight (kg)	Pack. /pcs
SO69.95	6418677414572	25-95	7-16.5	22	0.244	50

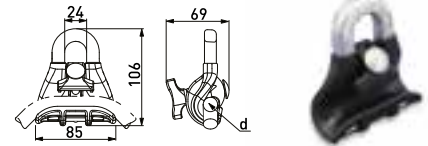

Tension clamp SO65.1

Used for the termination of insulated messenger wires. Insulation shall be peeled off before installation.

Product code	GTIN	Messenger mm ²	Messenger dia. mm	SMFL kN	Weight (kg)	Pack. /pcs
SO65.1	6418677404849	16-70	4.9-9.8	18.6 (70mm ²)	0.296	50

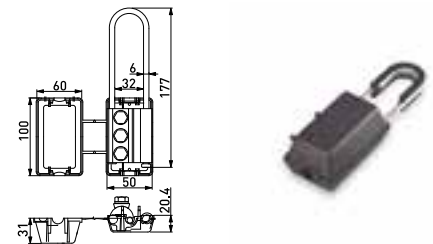

Tension clamp SO95

Used for the tensioning of all cables dia. 11-19 mm with round shape. Light weight, no loose parts. The clamp is easy to install, without cutting the cable. The body is made of weather and UV-radiation resistant thermoplastic and the bail of hot-dip galvanized steel.

Product code	GTIN	Cable dia. mm	SMFL kN	Weight (kg)	Pack. /pcs
SO95	6418677405174	11-19	0.75 (Ø11 mm), 2.0 (Ø19 mm)	0.1	50

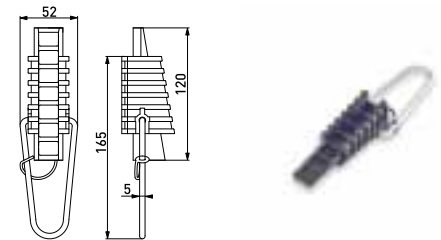

Tension clamp SO243

The SO243 is a tension clamp for four core service connections - made from weather durable and mechanically reliable polymeric plastic. The light weight design of SO243 provides extremely easy and quick anchoring of LV overhead cables - either to poles or walls by means of standard hooks. No tools are required during the installation.

Product code	GTIN	Conductor size mm ²	Conductor diameter mm	SMFL kN	Weight (kg)	Pack. /pcs
SO243	6418677437977	2-4x(6-25)	5.3-9.1	2	0.07	50

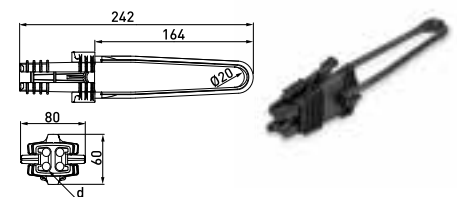

Uninsulated Messenger Wire system (AMKA)

Tension clamps SO3 and SO4

Used for tensioning of an uninsulated messenger (AMKA).

Product code	GTIN	Messenger mm ²	Messenger mm	SMFL kN	Colour code	Weight (kg)	Pack. /pcs
SO3.16	6418677414541	16	4.8	4	-	0.105	50
SO3.25	6418677404597	25	5.8	6.6	Orange	0.103	50
SO3.35	6418677404603	35	6.8	9.3	Red	0.103	50
SO3.50	6418677404627	50	8	13.2	Yellow	0.103	50
SO4.70	6418677404733	70	9.6	18.6	White	0.237	50
SO4.95	6418677404740	95	11.3	18.6	Black	0.237	50

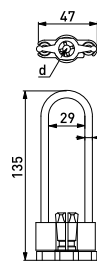

Tension clamp SO28

The messenger is fitted, the clamp opened, directly into the groove without cutting. SMFL various messenger cross-sections:

- 25 mm² - 6.6 kN
- 35 mm² - 9.3 kN
- 50 mm² - 13.2 kN

Product code	GTIN	Messenger mm ²	Messenger mm	SMFL kN	Tightening torque Nm	Weight (kg)	Pack. /pcs
SO28	6418677404580	25-50	5.8-8	13.2	20	0.247	50

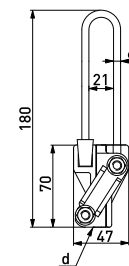

Tension clamp SO141

For suspending of LV ABC with uninsulated messenger (AMKA). The messenger is fitted, the clamp opened, directly into the groove without cutting. Clamp equipped with eye for cable hoist. SMFL for various messenger cross-sections are as follows:

- 16 mm² - 4.3 kN
- 25 mm² - 6.6 kN
- 35 mm² - 9.3 kN
- 50 mm² - 13.2 kN
- 70 mm² - 18.6 kN
- 95 mm² - 25.1 kN

Product code	GTIN	Messenger mm ²	Messenger mm	SMFL kN	Tightening torque Nm	Weight (kg)	Pack. /pcs
SO141	6418677404405	16-95	4.9-11.3	25.1	44	0.46	25

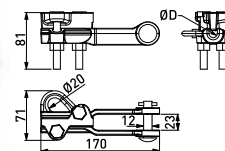

Terminal clamps SN2.2, SN3.3 and SN3.31

Terminal clamps are used for the termination of aluminium conductors to poles or walls.

Product code	GTIN	Messenger mm ²	Messenger mm	SMFL kN	Tightening torque nm	Weight (kg)	Pack. /pcs
SN2.2	6418677404009	AAAC 16-50	4.4-8.3	13.2 (50 mm ²)	20	0.096	100
SN3.3	6418677404016	AAAC 50-70	7.9-10	12.0 (50 mm ²), 12.0 (70 mm ²)	20	0.18	50
SN3.31	6418677416170	AAAC 50-95	7.9-11.7	25.1 (95 mm ²)	26	0.18	50

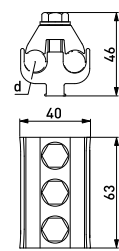

SN3.3



Tension clamp SO65

Used for tensioning of AAAC or uninsulated messenger wires (AMKA).

SMFL for various messenger cross-sections:

- 16 mm² - 4.3 kN
- 25 mm² - 6.6 kN
- 35 mm² - 9.3 kN
- 50 mm² - 13.2 kN
- 70 mm² - 18.6 kN

Product code	GTIN	Messenger mm ²	Messenger mm	SMFL kN	Tightening torque Nm	Weight (kg)	Pack. /pcs
SO65	6418677404832	25-70	4.9-9.8	19	25	0.23	50

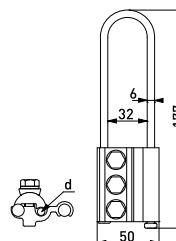

Suspension clamp SO214

Used for the suspension of overhead cables with uninsulated messenger in straight lines and angles up to 90°.

Product code	GTIN	Messenger mm ²	Messenger mm	SMFL kN	Tightening torque Nm	Weight (kg)	Pack. /pcs
SO214	6418677410666	16-95	4.8-13	25	48	0.248	50

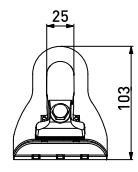



Insulation Piercing Connectors

Insulation piercing connector SLIW50

SLIW50 is for use with insulated aluminium or copper conductors. Fully insulated bolt provides safe live line working. Both main and branch conductor insulations are pierced by single bolt action. Test voltage 6 kV/50 Hz/1 min in water. Connector's design enables hot line installation without peeling insulation from conductor.

Product code	GTIN	Main conductor mm ²	Branch conductor mm ²	Conductor diameter mm	Weight (kg)	Pack. /pcs
SLIW50	6438100303921	10-50	1.5-10	6.1-12.5/3-7	0.05	120

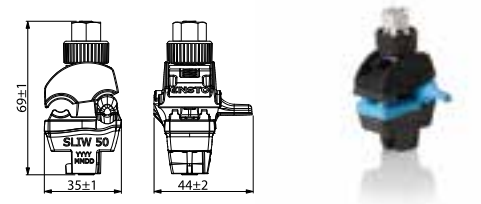

Insulation piercing connector SLIW52

SLIW52 is for use with insulated aluminium or copper conductors. Fully insulated bolt provides safe live line working. Both main and branch conductor insulations are pierced by single bolt action. Test voltage 6 kV/50 Hz/1 min in water. Connector's design enables live line installation without peeling insulation from conductor.

Product code	GTIN	Main conductor mm ²	Branch conductor mm ²	Conductor diameter mm	Weight (kg)	Pack. /pcs
SLIW52	6438100312114	16-150	1,5-16	7.0-18.6/ 3.0-7.8	0.062	60

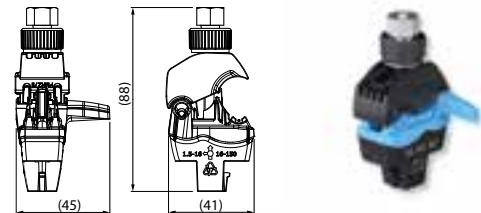

Insulation piercing connector SLIW54

SLIW54 is for use with insulated aluminium or copper conductors. Fully insulated bolt provides safe live line working. Both main and branch conductor insulations are pierced by single bolt action. Test voltage 6 kV/50 Hz/1 min in water. Connector's design enables hot line installation without peeling insulation from conductor.

Product code	GTIN	Main conductor mm ²	Branch conductor mm ²	Conductor diameter mm	Weight (kg)	Pack. /pcs
SLIW54	6438100303785	16-120	6-50	7-17.6/4-12.1	0.085	60

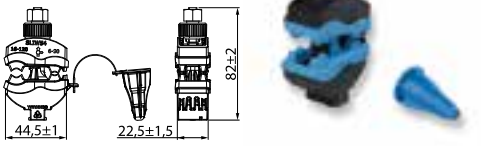

Insulation piercing connector SLIW56

SLIW56 is for use with insulated aluminium or copper conductors. Fully insulated bolt provides safe live line working. Both main and branch conductor insulations are pierced by single bolt action. Test voltage 6 kV/50 Hz/1 min in water. Connector's design enables live line installation without peeling insulation from conductor.

Product code	GTIN	Main conductor mm ²	Branch conductor mm ²	Conductor diameter mm	Weight (kg)	Pack. /pcs
SLIW56	6438100303792	25-150	6-35	8.0-18.6/ 4.0-10.9	0.075 kg	60

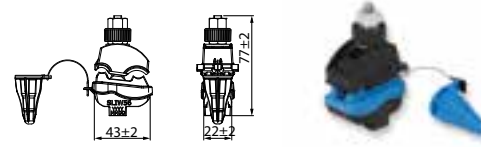

Insulation piercing connector SLIW57

SLIW57 is for use with insulated aluminium or copper conductors. Fully insulated bolt provides safe live line working. Both main and branch conductor insulations are pierced by single bolt action. Test voltage 4 kV/50 Hz/1 min in water. Connector's design enables hot line installation without peeling insulation from conductor.

Product code	GTIN	Main conductor mm ²	Branch conductor mm ²	Conductor diameter mm	Weight (kg)	Pack. /pcs
SLIW57	6438100303686	25-150	25-95	8.4-18.5/ 8.4-15.2	0.113	60

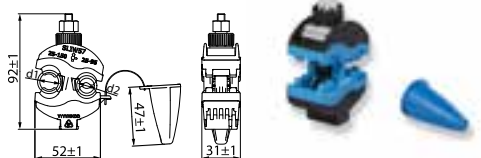

Insulation piercing connector SLIW58

SLIW58 is for use with insulated aluminium or copper conductors. Fully insulated bolt provides safe live line working. Both main and branch conductor insulations are pierced by single bolt action. Test voltage 6 kV/50 Hz/1 min in water. Connector's design enables live line installation without peeling insulation from conductor.

Product code	GTIN	Main conductor mm ²	Branch conductor mm ²	Conductor diameter mm	Weight (kg)	Pack. /pcs
SLIW58	6438100307387	50-150	50-150	12.5-18.5	0.139kg	60

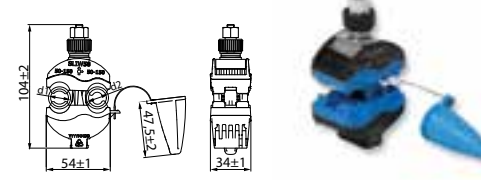

Insulation piercing connector SLIW59

SLIW59 is for use with insulated aluminium or copper conductors. LV ABC 70-150mm² to Sector cable 70-240 mm² connections. Fully insulated bolt provides safe live line working. Test voltage 6 kV/50 Hz/1 min in water. Connector's design enables live line installation without peeling insulation from conductor.

Product code	GTIN	Main conductor mm ²	Branch conductor mm ²	Conductor diameter mm	Weight (kg)	Pack. /pcs
SLIW59	6438100314637	70-150	70-240	9.3-22.8	0.51	12

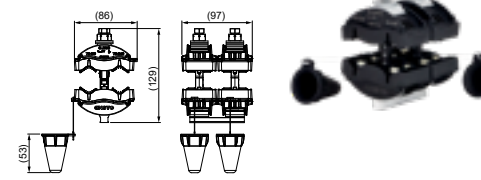

Insulation piercing connector SLIP12.05

The SLIP12.05 is used for all connections of insulated aluminium and copper main and branch conductors up to 1 kV. The design enables hot line installation. Equipped with shear head screw.

Product code	GTIN	Main conductor mm ²	Branch conductor mm ²	Conductor diameter mm	Tightening torque Nm	Weight (kg)	Pack. /pcs
SLIP12.05	6418677441783	10-50	1.5-50	3-12.1	21-26	0.1	50

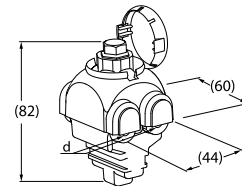

Insulation piercing connector SLIP12.1

The SLIP12.1 is used for all connections of insulated aluminium and copper main and branch conductors up to 1 kV. The design enables hot line installation. Equipped with shear head screw.

Product code	GTIN	Main conductor mm ²	Branch conductor mm ²	Conductor diameter mm	Tightening torque Nm	Weight (kg)	Pack. /pcs
SLIP12.1	6418677429033	10-95	1.5-50	3-16	21-26	0.1082	50

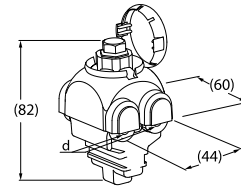

Insulation piercing connector SLIP12.127

SLIP12.127 is for all connections of uninsulated aluminium or copper main and insulated branch conductors up to 1 kV. Equipped with shear head screw.

Product code	GTIN	Main conductor mm ²	Branch conductor mm ²	Conductor diameter mm	Tightening torque Nm	Weight (kg)	Pack. /pcs
SLIP12.127	6418677446023	10-70	1.5-50	3-12.1	21-26	0.108	50

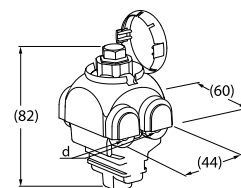

Insulation piercing connector SLIP22.1

The SLIP22.1 is for all connections of insulated aluminium and copper main and branch conductors up to 1 kV. The design enables hot line installation. The shear head is insulated from the bolt and the connector body. Equipped with shear head screw.

Product code	GTIN	Main conductor mm ²	Branch conductor mm ²	Conductor diameter mm	Tightening torque Nm	Weight (kg)	Pack. /pcs
SLIP22.1	6418677403842	Al 10-95 / Cu 1.5-70	Al 10-95 / Cu 1.5-70	3-16	21-26	0.124	50

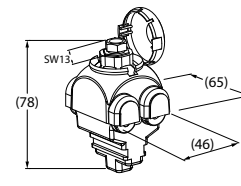

Insulation piercing connector SLIP22.127

SLIP22.127 is for all connections of uninsulated aluminium and copper main and insulated branch conductors up to 1 kV. Equipped with shear head screw.

Product code	GTIN	Main conductor mm ²	Branch conductor mm ²	Conductor diameter mm	Tightening torque Nm	Weight (kg)	Pack. /pcs
SLIP22.127	6418677416194	Al 25-95 / Cu 25-70	Al 2.5-95 / Cu 1.5-70	6.5-16 / 3-16	21-26	0.12	50

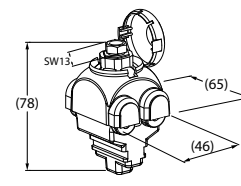

Insulation piercing connectors SLIP32.2 and SLIP32.21

The SLIP32.2 is for all connections of insulated aluminium and copper main and branch conductors up to 1000 VAC. The design enables hot line installation. The shear head is insulated from the bolt and the connector body. SLIP32.21 is for all connections of uninsulated aluminium and copper main and insulated branch conductors up to 1 kV. Equipped with shear head screw.

Product code	GTIN	Main conductor mm ²	Branch conductor mm ²	Conductor diameter mm	Tightening torque Nm	Weight (kg)	Pack. /pcs
SLIP32.2	6418677442001	Al 16-150 / Cu 16-150	Al 16-120 / Cu 16-95	7-19	17-19.5	0.15	50
SLIP32.21	6418677442018	Al/Cu 16-150	Al 16-120 / Cu 16-95	7-19	17-19.5	0.15	50

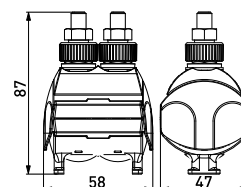

SLIP32.2





Insulation piercing connector SL11.118

Universal connector for all combinations of aluminium and copper main and branch connectors. SL11.118 is for PEX insulated conductor.

Product code	GTIN	Main conductor mm ²	Branch conductor mm ²	Conductor diameter mm	Tightening torque Nm	Weight (kg)	Pack. /pcs
SL11.118	6418677403538	Al 10-95 / Cu 1.5-70	Al 10-95 / Cu 1.5-70	3-16	26	0.121	50

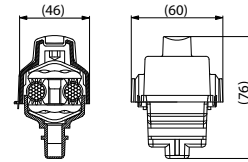

Reusable connectors SLIW65 and SLIW65S

Reusable connectors are specially designed for use with universal piercing connectors e.g. SLIW57 up to 1 kV. They allow service line disconnection without removing a main connector. SLIW65 and SLIW65S can be used with aluminium or copper conductors

Product code	GTIN	For conductor mm ²	Conductor diameter mm	Tightening torque Nm	Weight (kg)	Pack. /pcs
SLIW65	6438100312695	1x2.5-35	3.5-11	11	0,052	60
SLIW65S	6438100312701	1x2.5-35	3.5-11	11±1	0,052	60

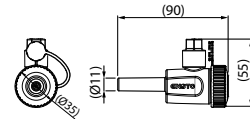

SLIW65



Insulation piercing connectors SLIW66 and SLIW67

Multitap connectors is specially designed for use with universal piercing connectors e.g. SLIW57, SLIW58, SL11.118, SLIP22.1,SLIP22.127 and SLIP32.2 up to 1000 V a.c. to facilitate several out-going conductors. Each branch conductor can be connected with a separate screw.

Product code	GTIN	Branch conductor mm ²	Conductor diameter mm	Tightening torque Nm	Weight (kg)	Pack. /pcs
SLIW66	6438100317973	2 x 6-35	4.5-11	10±1	0.1	40
SLIW67	6438100317980	4 x 6-35	4.5-11	10±1	0.2	20

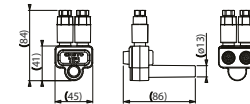

SLIW66

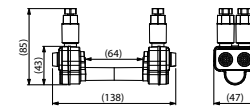

SLIW67



Insulation piercing connectors SL9.11 and SL9.2

SL9.11 is equipped with springs made of stainless steel to make the installation easier. SL9.11 is with one bolt. SL9.22 is equipped with a threaded hole for a surge arrester. The connector has teeth in one groove only. Allen type screw.

Product code	GTIN	Main conductor mm ²	Branch conductor mm ²	d1 mm	d2 mm	Tightening torque Nm	Weight (kg)	Pack. /pcs
SL9.11	6418677403804	Al 16-120	Al 16-35	7-18	4.6-7.5	20	0.1	50
SL9.21	6418677403828	Al 16-120	Al 16-95	7-18	4.6-12	20	0.163	50
SL9.22	6418677403835	Al 16-120	Al 16-95	7-18	4.6-12	20	0.15	50

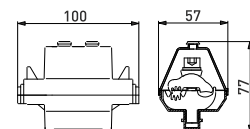

SL9.11

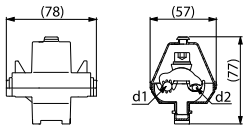

SL9.21



End caps PK99

Grease filled end caps are used for preventing water entry from the end of the branch cable.

Product code	GTIN	Conductor size mm ²	Conductor diameter mm	Weight (kg)	Pack. /pcs
PK99.025	6418677400995	10-25	7.0-9.4	0.003	1000
PK99.050	6418677401008	35-50	9.8-12.0	0.004	500
PK99.095	6418677401015	70-95	12.9-16.0	0.007	400
PK99.2595	6418677401039	25-95	8.4-18.0	0.006	300

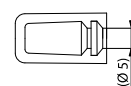
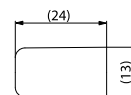

PK99.025



End cap PK553

PK553 is used for preventing water entry into the end of the branch cable.

Product code	GTIN	Conductor size mm ²	Conductor diameter mm	Weight (kg)	Pack. /pcs
PK553	6438100306892	4-50	4.0-13.0	0.0042	120

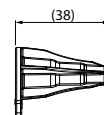

End cap PK555

PK555 is used for preventing water entry into the end of the branch cable.

Product code	GTIN	Conductor size mm ²	Conductor diameter mm	Weight (kg)	Pack. /pcs
PK555	6438100306908	25-150	8.0-19.0	0.0072	120

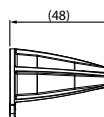

Aluminium to aluminium parallel groove connectors

Aluminium to aluminium connectors SL37.1 and SL37.2

Non tension aluminium to aluminium connector SL37.1 is equipped with one M8 bolt. Non tension aluminium to aluminium connector SL37.2 is equipped with two M8 bolts.

Product code	GTIN	Main conductor mm ²	Branch conductor mm ²	Conductor diameter mm	Tightening torque Nm	Plastic cover	Weight (kg)	Pack. /pcs
SL37.1	6418677414404	Al 6-95	Al 6-95	3-13 / 3-13	22	SP15	0.055	200
SL37.2	6418677414411	Al 6-95	Al 6-95	3-13 / 3.5-13	22	SP15	0.1	50

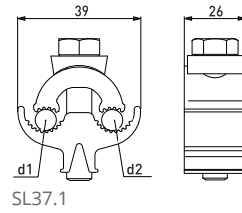

Aluminium to aluminium connectors SL37.201

Non tension aluminium to aluminium connector SL37.201 is equipped with two M8 shear head bolts.

Product code	GTIN	Main conductor mm ²	Branch conductor mm ²	Conductor diameter mm	Tightening torque Nm	Plastic cover	Weight (kg)	Pack. /pcs
SL37.201	6418677414602	Al 6-95	Al 6-95	3-13 / 3.5-13	22	SP15	0.1	50

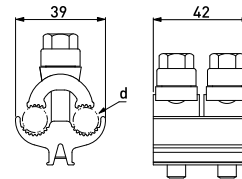

Aluminium to aluminium connectors SL39.2

Non tension aluminium to aluminium LV and MV connections. The SL39.2 connector is suitable for AAC, AAAC and ACSR conductors. Equipped with two M8 bolts.

Product code	GTIN	Main conductor mm ²	Branch conductor mm ²	Conductor diameter mm	Tightening torque Nm	Plastic cover	Weight (kg)	Pack. /pcs
SL39.2	6418677419607	Al 16-150	Al 16-150	4.5-17.5	22	SP15	0.12	50

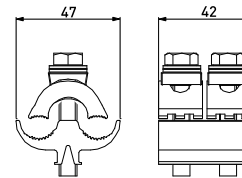

Aluminium to aluminium connector SL2.11

SL2.11 is brushed and prepared with a joint compound and thus, only the conductors need brushing and greasing. The connector is packed in individual plastic bags. Non tension aluminium to aluminium connections.

Product code	GTIN	Main conductor mm ²	Branch conductor mm ²	Conductor diameter mm	Tightening torque Nm	Plastic cover	Weight (kg)	Pack. /pcs
SL2.11	6418677403606	Al 16-50	Al 16-50	4.6-8.6	20	SP14	0.052	200

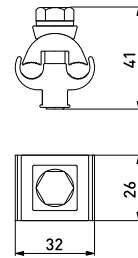

Aluminium to aluminium connectors SL4.21, SL4.25 and SL8.21

SL4.21 and SL8.21 are brushed and prepared with joint compound; thus only the conductors need brushing and greasing. SL4.25 is equipped with springs.

Product code	GTIN	Main conductor mm ²	Branch conductor mm ²	Conductor diameter mm	Tightening torque Nm	Plastic cover	Weight (kg)	Pack. /pcs
SL4.21	6418677403736	Al 16-120	Al 16-120	4.21-13.2	20	SP15	0.13	50
SL4.25	6418677403750	Al 16-120	Al 16-120	4.6-13.5	20	SP15	0.128	50
SL8.21	6418677403781	Al 50-240	Al 50-240	7.7-20	44	SP16	0.29	25



SL4.21

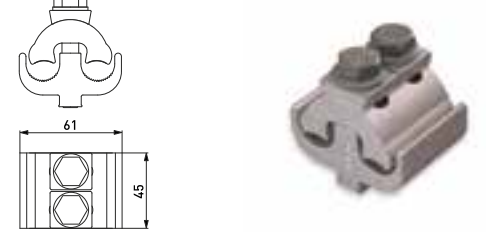

SL8.21

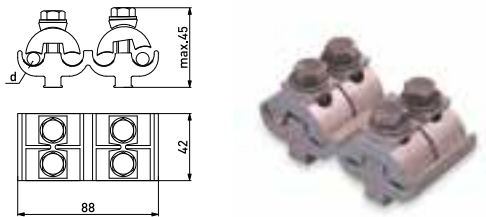

SP24

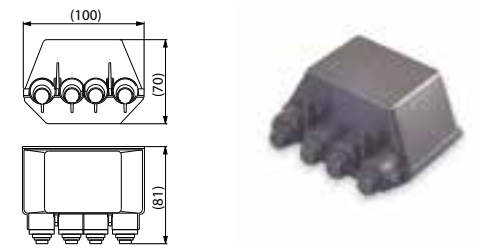

Multi-connector SL19.4

Branching of 1-3 out-going cables, max. Al 120 mm².

Product code	GTIN	Main conductor mm ²	Branch conductor mm ²	Conductor diameter mm	Tightening torque Nm	Plastic cover	Weight (kg)	Pack. /pcs
SL19.4	6418677403583	Al 16-120	Al 16-120	4.6-13.5	20	SP24, SP25	0.25	25

Insulation covers SP24 and SP25

SP24 is used for the branching of 1-3 out-going cables, max. 120 mm² Al. The insulation cover is made of weather and UV-radiation resistant thermoplastic. SP24 has cable outlets only in one end. Suitable for SL19.4. SP25 is used for the branching of 1-3 out-going cables, max. 120 mm² Al. The insulation cover is made of weather and UV-radiation resistant thermoplastic. SP 25 has cable outlets in both ends.

Product code	GTIN	For connectors	Weight (kg)	Pack. /pcs
SP24	6418677405259	SL19.4	0.04	25
SP25	6418677408175	SL19.4	0.04	25



Surge Arresters with Insulation Piercing Connectors SE45 and SE46

Surge arresters with insulation piercing connectors SE45

SE45 serie includes a new piercing connector specially designed for surge arrester. This connector is used when installing the surge arrester on insulated LV overhead lines. It can be installed on insulated Al/Cu conductors with cross section range 10-150 mm². Continuous operating voltage 280V.

Product code	GTIN	Surge arrester	Disconnecter	Weight (kg)	Pack. /pcs
SE45.275-15	6438100326715	SGA275-15	+	0.22	15
SE45.440-15	6438100326722	SGA440-15	+	0.22	20
SE45.690-15	6438100326739	GA690-15	+	0.22	20



SE45.275-15

Surge arresters with insulation piercing connectors SE46

The design of SE46 serie enables installation on insulated conductor and branch connection, the same connector is used for both. Connector can be installed on insulated Al conductors with cross section range 10 - 95 mm² and Cu conductors with cross section range 1.5 - 70 mm² and branch connection with the same range of conductors.

Product code	GTIN	Surge arrester	Disconnecter	Weight (kg)	Pack. /pcs
SE46.275-15	6438100326685	SGA275-15	+	0.26	20
SE46.440-15	6438100326692	GA440-15	+	0.26	20
SE46.690-15	6438100326708	SGA690-15	+	0.26	20



SE46.275-15

Aluminium to Copper Parallel Groove Connectors

Aluminium to copper connectors SM1.11, SM2.11, SM2.21, SM2.25 and SM4.21

The connectors are brushed and prepared with joint compound; thus only the conductors need brushing and greasing. SM2.25 ia equipped with springs to make the installation easier.

Product code	GTIN	Main conductor mm ²	Branch conductor mm ²	Conductor diameter mm	Tightening torque Nm	Plastic cover	Weight (kg)	Pack. /pcs
SM1.11	6418677403880	Al 10-50	Cu 1.5-10	3.5-8.6/ 1.35-3.6	20	SP14	0.054	200
SM2.11	6418677403903	Al 16-95	Cu 2.5-25	4.6-10/ 2.3-6.5	20	SP15	0.084	100
SM2.21	6418677403927	Al 16-120	Cu 6-35	4.6-13.2/ 2.8-7.5	20	SP15	0.14	50
SM2.25	6418677403941	Al 16-120	Cu 6-35	4.6-13.2/ 2.8-7.5	20	SP15	0.137	50
SM4.21	6418677403965	Al 50-240	Cu 10-95	8.6-20/ 3.5-12.5	44	SP16	0.326	25



SM2.11

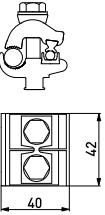

SM2.21

SM2.21

Aluminium / copper to aluminium / copper connectors SL4.26, SL14.2 and SL37.27

For Al or Cu to Al or Cu connections where no mechanical tension is involved. The body is made from tin plated aluminium alloy, and the bolts are hot-dip galvanized steel.

Product code	GTIN	Main conductor mm ²	Branch conductor mm ²	Conductor diameter mm	Tightening torque Nm	Plastic cover	Weight (kg)	Pack. /pcs
SL4.26	6418677403767	Al/Cu 16-120	Al 16-120 / Cu 16-95	4.6-14	20	SP15	0.125	50
SL14.2	6418677403552	Al/Cu 50-240	Al 50-185 / Cu 50-150	7.7-20	44	SP16	0.28	25
SL37.17	6418677436116	Al/Cu 6-95	Al 6-95 / Cu 6-70	3-13	22	SP15	0.055	200
SL37.27	6418677416118	Al/Cu 6-95	Al/Cu 6-95	3-13	22	SP15	0.1	50
SL39.27	6418677438905	Al/Cu 16-150	Al 16-150 / Cu 10-120	4.5-17.5	22	SP15	0.12	50

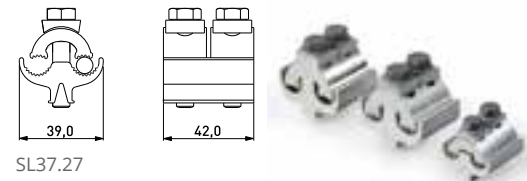

Aluminium / copper to aluminium / copper connectors SL37.271

Non tension aluminium/copper to aluminium/copper connections. SL37.271 is for Al or Cu connections where no mechanical tension is involved. The body is made of tin plated aluminium alloy, and the bolts are shear head bolts which are hot-dip galvanized steel.

Product code	GTIN	Main conductor mm ²	Branch conductor mm ²	Conductor diameter mm	Tightening torque Nm	Plastic cover	Weight (kg)	Pack. /pcs
SL37.271	6418677450273	Al/Cu 6-95	Al 6-95 / Cu 6-70	3-13	22	SP15	0.11	50

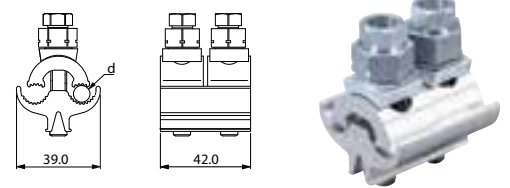

Aluminium / copper to aluminium / copper connectors SL39.271

Non tension aluminium to aluminium LV and MV connections. The SL39.271 connector is suitable for AAC, AAAC and ACSR conductors. Equipped with two M8 shear head bolts.

Product code	GTIN	Main conductor mm ²	Branch conductor mm ²	Conductor diameter mm	Tightening torque Nm	Plastic cover	Weight (kg)	Pack. /pcs
SL39.271	6418677450280	Al/Cu 16-150	Al 16-150, Cu 10-120	4.5-17.5	22	SP15	0.13	50

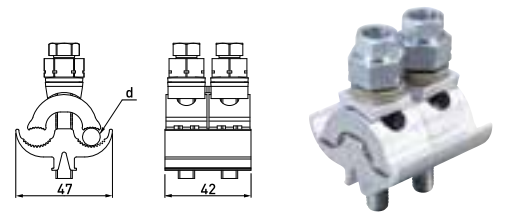

Copper to copper crimp connector SE36

SE36 is for copper to copper connections where also mechanical tension can be involved. The massive C-formed connector secures continuous electrical contact and low resistance.

Product code	GTIN	Conductor size mm ²	Conductor diameter mm	Tightening torque Nm	Weight (kg)	Pack. /pcs
SE36	6418677402043	Cu 10-25	-		0.019	100

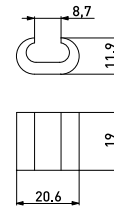

Copper to copper connector SE12.1

The SE12.1 is for copper to copper connections where no mechanical tension is involved or for the connection of an earthing conductor. The connector is made of copper and the bolt is stainless steel.

Product code	GTIN	Main conductor mm ²	Branch conductor mm ²	Conductor diameter mm	Tightening torque Nm	Weight (kg)	Pack. /pcs
SE12.1	6418677401831	Cu 16-70	Cu 10-50	4.5-10.7	20	0.116	100

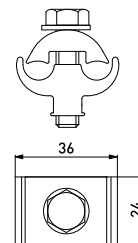

Copper to copper connector SE12.101

The SE12.101 is for copper to copper connections where no mechanical tension is involved or for the connection of an earthing conductor. The connector is made of copper and the bolt is stainless steel with shear head nut.

Product code	GTIN	Main conductor mm ²	Branch conductor mm ²	Conductor diameter mm	Tightening torque Nm	Weight (kg)	Pack. /pcs
SE12.101	6418677450136	Cu 16-70	Cu 10-50	4.5-10.7	20	0.121	100

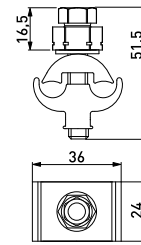

Insulating cover SP14

SP14 is used as a connector cover. The cover has to be installed so that the drain hole for ambient water is downwards. The cover is made of UV-radiation and weather resistant thermoplastic. Suitable for SM1.1, SM1.11, SM2.1, SL2.11.

Product code	GTIN	For connectors	Weight (kg)	Pack. /pcs
SP14	6418677405204	SM1.1; SM1.11; SL2.1; SL2.11	0.014	100

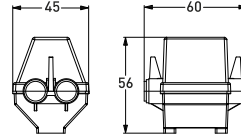

Insulating cover SP15

SP15 is used as a connector cover. The cover has to be installed so that the drain hole for ambient water is downwards. The cover is made of UV-radiation and weather resistant thermoplastic. Suitable for SM2.1, SM2.11, SM2.2, SM2.21, SM2.25, SL4.2, SL4.21, SL4.25, SL4.26, SL37.1, SL37.2, SL39.2.

Product code	GTIN	For connectors	Weight (kg)	Pack. /pcs
SP15	6418677405211	SM2.xx; SL3.xx; SL4.xx; SL37.xx; SL39.xx	0.031	100

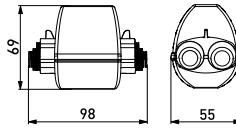

Insulating cover SP16

SP16 is used as a connector cover. The cover has to be installed so that the drain hole for ambient water is downwards. The cover is made of UV-radiation and weather resistant thermoplastic. Suitable for SM4.2, SM4.21, SL8.2, SL8.21, SL14.2, SL25.2, series SE20, SE21.

Product code	GTIN	For connectors	Weight (kg)	Pack. /pcs
SP16	6418677410208	SM4.xx; SL8.xx; SL14.2; SLW25.2; SEW20.xx; SEW21.xx	0.037	50

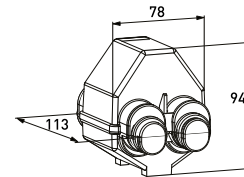

Automatic tension joints and joint kits

The automatic joint is reliable and quick to make. No tools are needed for the installation and with the colour code, you can find the correct size easily. The wedges ensure a safe joint.

Product code	GTIN	For conductor mm ²	Conductor diameter mm	Colour code	Weight (kg)	Pack. /pcs
CIL63	6418677414220	35 - 50	5.81-8.64	orange / red	0.155	25
CIL64	6418677414237	70 - 95	9.27-12.06	yellow / grey	0.278	25
CIL65	6418677414244	120 - 150	12.75-14.86	pink / black	0.478	25
CIL71	6418677417726	-	14.73-18.4	green / brown	0.840	10
CIL72	6418677418440	-	18.8-21.7	blue / green	1.08	10

Joint kits CIL66, 67 and 68 include a joint, an insulation sleeve and an abrasive tape.

CIL66	6418677414251	PAS 35-50	5.81-8.6	orange/red	0.26	25
CIL67	6418677414268	PAS 70-95, BLL 62	9.27-12.06	yellow/grey	0.47	25
CIL68	6418677414275	PAS 120-150, BLL 99	12.75-14.86	pink/black	0.79	25



CIL68

CIL63



Busbar Connectors

Busbar Connector KG71

The KG71 is used for connecting insulated Al- and Cu-conductors without stripping to aluminium busbars in distribution boards, disconnectors, medium and low voltage transformer bushings. Max thickness of the bar 7.5 mm.

Product code	GTIN	Conductor size mm ²	Conductor diameter mm	Tightening torque Nm	Max thickness of the bar mm	Bolts	Weight (kg)	Pack. /pcs
KG71	6418677400322	Al 16-120 / Cu 10-95	6-18	20	7.5	2 x M8	0.205	50

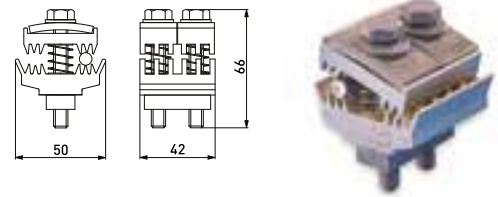

Busbar connectors KG6.1, KG41 and KG16

For connecting Al-conductors to aluminium busbars or tin plated copper busbars in distribution boards, disconnectors, medium and low voltage transformer bushings.

Product code	GTIN	Conductor size mm ²	Conductor diameter mm	Tightening torque Nm	Max thickness of the bar mm	Bolts	Weight (kg)	Pack. /pcs
KG6.1	6418677400308	Al 16-70	4.6-10.2	20	10	2 x M8	0.12	50
KG41	6418677400230	Al 2x(16-120)	4.6-14	20	7.5	2 x M8	0.165	50
KG16	6418677400131	Al 16-120	4.6-14	40	10	2 x M10	0.258	25



Busbar Connector KG43

The KG43 connector is used for connecting Al-conductors to aluminium busbars or tin plated copper busbars in distribution boards, disconnectors, medium and low voltage transformer bushings. Max thickness of the bar 10 mm.

Product code	GTIN	Conductor size mm ²	Conductor diameter mm	Tightening torque Nm	Max thickness of the bar mm	Bolts	Weight (kg)	Pack. /pcs
KG43	6418677400254	Al 50-240	7.7-20	40	10	2 x (M10x75)	0.329	25

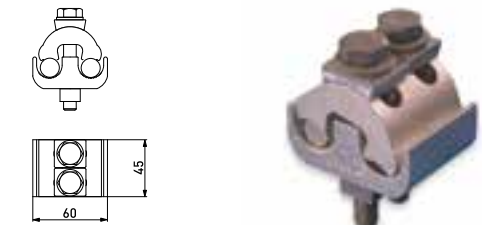

Busbar connectors KG26 and KG26.4

The KG26 and KG26.4 connectors are used for connecting Al-conductors to aluminium busbars or tin plated copper busbars in distribution boards, disconnectors, medium and low voltage transformer bushings.

Product code	GTIN	Conductor size mm ²	Conductor diameter mm	Tightening torque Nm	Max thickness of the bar mm	Bolts	Weight (kg)	Pack. /pcs
KG26	6418677400209	Al 120-300	14-22.5	70	15	2 x M12	0.745	10
KG26.4	6418677400216	4 x Al 70-120	9.3-14	70	15	2 x M12	0.805	10



Busbar connector KG44

The KG 44 connector is used for connecting Al/Cu-conductors to aluminium busbars or tin plated copper busbars in distribution boards, disconnectors, medium and low voltage transformer bushings. Max thickness of the bar 7.5 mm.

Product code	GTIN	Conductor size mm ²	Conductor diameter mm	Tightening torque Nm	Max thickness of the bar mm	Bolts	Weight (kg)	Pack. /pcs
KG44	6418677400261	Al 16-120 / Cu 6-35	Al 4.4-12.8 / Cu 2.8-7.5	20	7.5	2 x M8	0.173	50



Busbar connector KG20

For connecting Cu-conductors to copper busbars in distribution boards, disconnectors, medium and low voltage transformer bushings.

Product code	GTIN	Conductor size mm ²	Conductor diameter mm	Tightening torque Nm	Max thickness of the bar mm	Bolts	Weight (kg)	Pack. /pcs
KG20	6418677400186	Cu 16-185	4.5-17.5	22	7.5	2 x M8	0.153	50

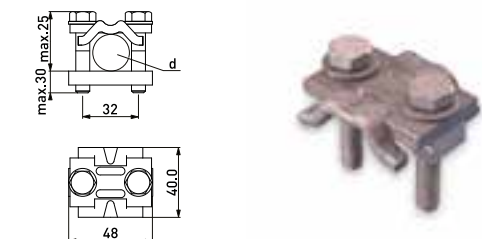



Copper Bars

Copper bars are used together with busbar connectors to connect Cu- or Al-conductors to high- or low voltage transformer bushings. It is important to brush and grease the Al-connections. Flat copper bars are tin-plated to reduce corrosion between aluminium and copper. The copper bars and connectors are delivered separately.



Product code	GTIN	Busbar cross section mm ²	Max current A	Hole diameter mm	For connectors	Weight (kg)	Pack. /pcs
PSS10	6418677401138	150	400	14	All except KG26	0.097	100
PSS85	6418677401350	250	600	22	KG6, KG16, KG41, KG43, KG44, KG20	0.21	50
PSS85.5	6418677401367	250	600	14/22	KG6, KG16, KG41, KG43, KG44, KG20	0.266	50
PSS310	6418677401220	400	950	22	KG26	0.414	25
PSS127	6418677401183	150	400	14	All except KG26	0.145	50
PSS242	6418677401190	250	600	22	All except KG26 and KG20	0.349	25
PSS309	6418677401213	400	950	22	KG26, KG20	0.62	25
PSS309.5	6418677406560	400	950	14/22	KG26, KG20	0.683	25
PSS242.5	6418677401206	250	600	14/22	All except KG26	0.393	25

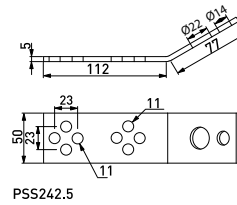
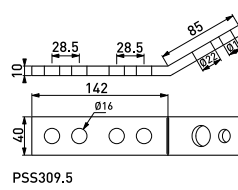
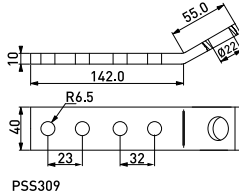
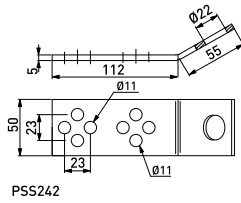
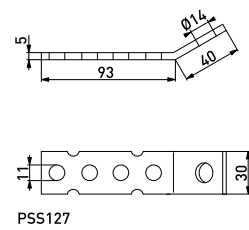
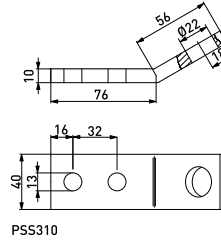
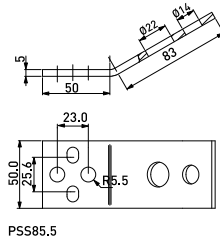
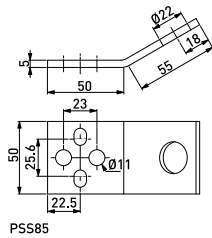
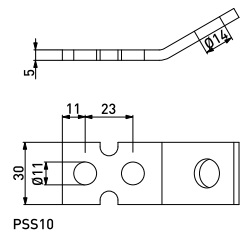

Cable Lugs, Cable joints, Earthing Connectors and Earthing Bars

Flexible bird protector set SP38.3

Flexible cover for low voltage bushings, transformers and motors. Easy tie fixing. Made of weather and UV resistant rubber. Delivered in complete sets of 3 pcs.

Product code	GTIN	Weight (kg)	Pack. /pcs
SP38.3	6418677405297	0.4	10

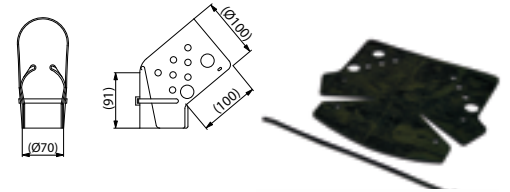

Cable lugs KG9, KG17 and KG18

Used for connecting Al-conductors to distribution boards, components and flat bars. The connections have to be brushed and greased. The aluminium parts of the cable lugs are made of corrosion-resistant aluminium alloy with a tensile strength of 300 N/mm². The bolts are hot-dip galvanized and class 8.8. The copper bars are tin-plated.

Product code	GTIN	Conductor size mm ²	Conductor diameter mm	Tightening torque Nm	Weight (kg)	Pack. /pcs
KG9	6418677400346	Al 2x(16-70)	4.5-10.2	20	0.19	50
KG17	6418677400155	Al 2x(35-120)	6.6-14	40	0.36	25
KG18	6418677400179	Al 2x(50-240)	7.7-20	40	0.465	20

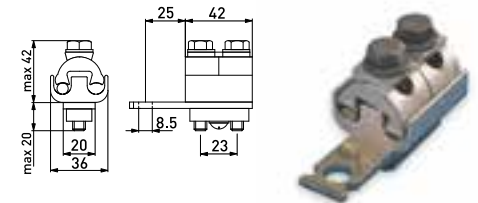

KG9

Cable lug KG50

Used for connecting Al or Cu conductors to Al or Cu bars in distribution boards and components.

Product code	GTIN	Conductor size mm ²	Conductor diameter mm	Tightening torque Nm	Weight (kg)	Pack. /pcs
KG50	6418677400278	1x16-95/2x16-35	4.5-12.5	10	0.101	100

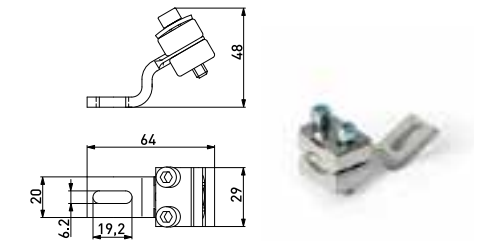

LUG shear head bolt cable lugs

The cable lugs are used for terminating conductors of up to 1 kV cables. Because of the shear head bolt construction, no crimping tools are needed. The required torque is achieved by tightening the bolt until it breaks off. The lugs are water tight and suitable for solid and stranded, sector shaped and circular conductors.

Product code	GTIN	Conductor size mm ²	L1 mm	L2 mm	L3 mm	B mm	d mm	D1 mm	D2 mm	H mm	SW mm	Weight (kg)
LUG6-50/8LV	6438100321895	Al 6-50	33	50	60	20	10	20	8.5	5.5	11	0.04
LUG6-50/8LVTIN	6438100321901	Al 6-50, Cu 6-35	33	50	60	20	10	20	8.5	5.5	11	0.04
LUG6-50/10LVTIN	6438100321918	Al 6-50, Cu 6-35	33	50	60	20	10	20	10.5	5.5	11	0.04
LUG6-50/12LVTIN	6438100321925	Al 6-50, Cu 6-35	33	50	60	20	10	20	12.5	5.5	11	0.04
LUG50-95/10LV	6438100321932	Al 50-95	50	73	86	25	14.5	25	10.5	7	14	0.08
LUG50-95/10LVTIN	6438100321949	Al 50-95, Cu 50-70	50	73	86	25	14.5	25	10.5	7	14	0.08
LUG50-95/12LVTIN	6438100321956	Al 50-95, Cu 50-70	50	73	86	25	14.5	25	12.5	7	14	0.08
LUG50-95/14LVTIN	6438100321963	Al 50-95, Cu 50-70	50	73	86	25	14.5	25	14	7	14	0.08
LUG95-185/12LV	6438100321970	Al 95-185	59	85	101	30	19	30	12.5	11	18	0.13
LUG95-185/12LVTIN	6438100321987	Al 95-185, Cu 95-150	59	85	101	30	19	30	12.5	11	18	0.13
LUG95-185/14LVTIN	6438100322007	Al 95-185, Cu 95-150	59	85	101	30	19	30	14	11	18	0.13
LUG95-185/16LVTIN	6438100321994	Al 95-185, Cu 95-150	59	85	101	30	19	30	16.5	11	18	0.13
LUG150-300/12LV	6438100322014	Al 150-300	71	111	132	42	25	42	12.5	13	22	0.33
LUG150-300/12LVTIN	6438100322021	Al 150-300, Cu 150-240	71	111	132	42	25	42	12.5	13	22	0.33
LUG150-300/16LVTIN	6438100322038	Al 150-300, Cu 150-240	71	111	132	42	25	42	16.5	13	22	0.33

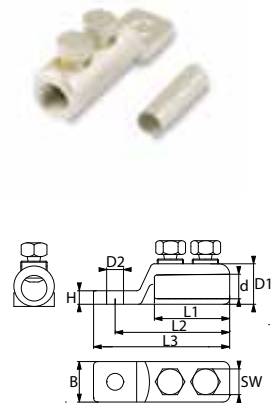



SLJ shear head bolt connectors and SJ screw connectors

The connectors are used for jointing conductors of up to 1 kV cables. Because of the shear head bolt construction, no crimping tools are needed. The required torque of SLJ connectors is achieved by tightening the bolt until it breaks off. SJ0.47 has non-breaking screws. The connectors are water tight and suitable for solid and stranded, sector shaped and circular, conductors. The core insulation may be plastic or paper.



Product code	GTIN	Conductor size mm ²	No. of screws	L1 mm	L2 mm	d mm	D mm	Weight (kg)
SLJ0.27	6438100335281	Al 10-35 Cu 4-25	2	17,5	40	8	14	0.018
SLJ0.47	6438100325565	Al 10-35 Cu 4-25	4	24	50	8	14	0.022
SLJ1.27	6418677458187	Al/Cu 6-50	2	26	54	11	20	0.034
SLJ1.47	6438100306663	Al/Cu 6-50	4	39	80	11	20	0.062
SLJ2.27	6418677458194	Al/Cu 35-95	2	23.5	58	16	27.5	0.067
SLJ2.47	6438100306670	Al/Cu 35-95	4	38.5	88	16	27.5	0.239
SLJ3.47	6418677459726	Al/Cu 95-240	4	58	119	25.5	37.7	0.278
SLJ4.47	6418677459733	Al/Cu 150-300	4	63.5	130	43	42.6	0.382

Earthing connector set SE15

SE15 consists of earthing connector SM2.24, earthing connector support PSS116, and two fixing bolts for wooden poles.

Product code	GTIN	Main conductor mm ²	Branch conductor mm ²	Conductor diameter mm	Tightening torque Nm	Weight (kg)	Pack. /pcs
SM2.24	6418677403934	Fe/Al 16-120	Cu 6-35	4.5-14 / 2.8-7.5	20	0.18	25
PSS116	6418677401176					0.153	50
SE15	6418677401848	Fe/Al 16-120	Cu 6-35	4.5-14 / 2.8-7.5	20	0.37	25

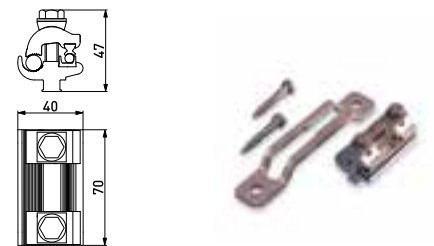

Earthing bars PSS396 and PSS396.1

Used for the connection of earthings in pole transformer stations. The earthing conductors can be connected to the bar by using KG connectors as follows: Cu 16-185 mm² : KG20, Al 16-120 mm² : KG16, Al 50-240 mm² : KG43.

Product code	GTIN	Busbar cross section mm ²	Connectors	Weight (kg)	Pack. /pcs
PSS396	6418677401237	50	5 pcs	0.291	50
PSS396.1	6418677401244	50	3 pcs	0.216	50

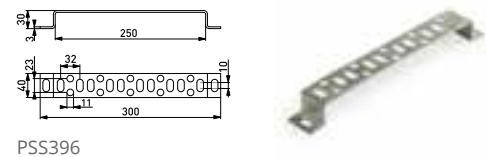

Earthing bar PSS431

Used for the connection of earthings in pole transformer stations. The busbars and the screws are tin-plated copper.

Product code	GTIN	Conductor size mm ²	Tightening torque Nm	Weight (kg)	Pack. /pcs
PSS431	6418677401251	5 x 50	10	0.11	25

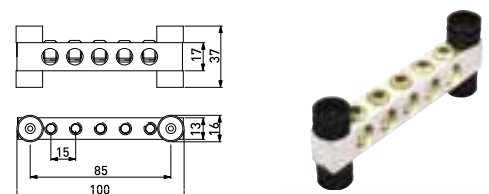

Earthing bar PSS874

The PSS874 is used to connect earthing conductors in transformer stations.

Product code	GTIN	Conductor size mm ²	Tightening torque Nm	Weight (kg)	Pack. /pcs
PSS874	6418677446085	10 x 50	10	0.2	25

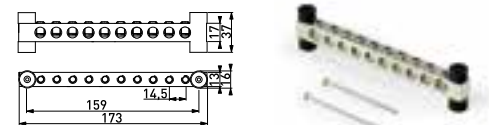

Temporary earthing bail set ST208.57

ST208.57 is used to prepare a point for temporary earthing in an ABC cable. Comes with an insulation piercing connector SLIW57.

Product code	GTIN	Conductor size mm ²	Weight (kg)	Pack. /pcs
ST208.57	6438100309916	Al/Cu 25-150 mm ² / 25-95 mm ²	0.17	20



Temporary earthing set ST202.54

Preparing temporary earthing and measuring point in an ABC line. Enable to earthing LV phases with usage of appropriate grounding device. Connector includes removable phase indicators.

Product code	GTIN	Conductor size mm ²	Weight (kg)	Pack. /pcs
ST202.54	6438100323004	Al/Cu 16-120	0.17	20

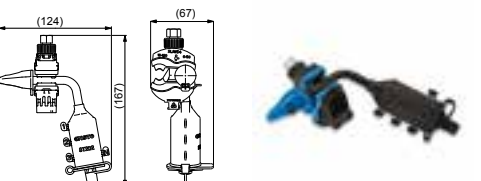

Pole fuse switch disconnectors 160 A 415 V

Pole fuse switch disconnecter SZ160.1

Pole fuse switches include separate terminal covers for in-coming and out-going conductors, thus making installation safer.

Product code	GTIN	Number of poles	Conductor size mm ²	Connectors included	Weight (kg)	Pack. /pcs
SZ160.1	6438100318307	1	Al (16x120)	2xKG45	1.8	1

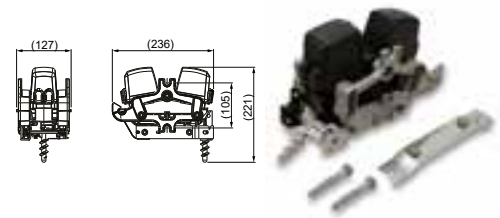

Pole fuse switch disconnecter SZ160.3 and SZ160.32

Pole fuse switches include separate terminal covers for in-coming and out-going conductors, thus making installation safer.

Product code	GTIN	Number of poles	Conductor size mm ²	Connectors included	Weight (kg)	Pack. /pcs
SZ160.3	6438100318314	3	Al 2x(16-120)/ Cu 2x(16-120)	6xKG45.5	3.17	1
SZ160.32	6438100318321	3+PEN	Al 2x(16-120)/ Cu 2x(16-120)	7xKG45.5	3.9	1

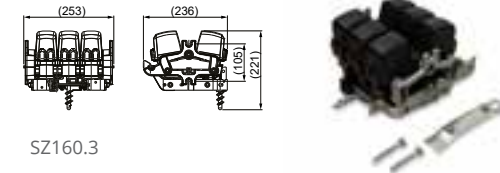

Pole fuse switch disconnecter SZ160.4

Pole fuse switches include separate terminal covers for in-coming and out-going conductors, thus making installation safer.

Product code	GTIN	Number of poles	Conductor size mm ²	Connectors included	Weight (kg)	Pack. /pcs
SZ160.4	6438100318338	4	Al 2x(16-120)/ Cu 2x(16-120)	8xKG41	4.8	1
SZ160.41	6438100318345	3+PEN	Al 2x(16-120)/ Cu 2x(16-120)	8xKG45.5	4.8	1

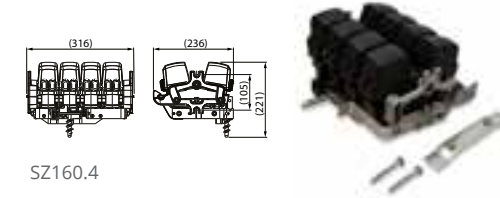

Connectors for 160 A pole fuse switches: KG41, KG44 and KG71

Pole fuse switches can be supplied with or without connectors:

- KG 41 for Al conductors,
- KG 71 insulation piercing connector
- KG 44 for Al/Cu conductors, for both Al and Cu conductors

Product code	GTIN	Conductor size mm ²	Conductor diameter mm	Tightening torque Nm	Weight (kg)	Pack. /pcs
KG41	6418677400230	Al 2x(16-120)	4.6-14	20	0.165	50
KG44	6418677400261	Al 16-120/ Cu 6-35	Al 4.4-12.8/ Cu 2.8-7.5	20	0.173	50
KG71	6418677400322	Al 16-120/ Cu 10-95	6-18	20	0.205	50

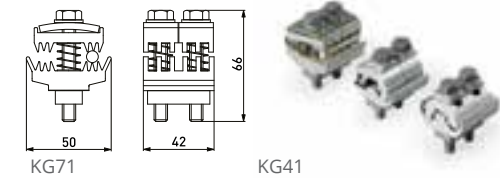

Pole fuse switch disconnectors 400 A 500 V

Pole fuse switch disconnector SZ400.3

For protecting stranded overhead cables and underground cables in LV-networks. Fuse-switch can be operated from the ground level by using operating rods.

Product code	GTIN	Number of poles	Conductor size mm ²	Connectors included	Weight (kg)	Pack. /pcs
SZ400.3	6438100328689	3	Al 2x(50-240)/ Cu2x(50-240)	6xKG43	9,9	1
SZ400.322	6438100328726	3	Al 2x(50-240)/ Cu2x(50-240)	3xKG43	9,1	
SZ400.33	6438100328719	3	Al 2x(50-240)/ Cu2x(50-240)	3xKG43	9,1	1

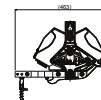
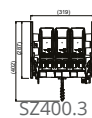

Pole fuse switch disconnector SZ400.4

For protecting stranded overhead cables and underground cables in LV-networks. Fuse-switch can be operated from the ground level by using operating rods. The fourth pole is there for extra phase conductor. It is opened and closed together with the other phase-poles. Connectors included 8 x KG43, poles 4

Product code	GTIN	Number of poles	Conductor size mm ²	Connectors included	Weight (kg)	Pack. /pcs
SZ400.4	6438100328696	4	Al 2x(50-240)/ Cu2x(50-240)	8xKG43	12,5	1
SZ400.41	6438100328702	3+PEN	Al 2x(50-240)/ Cu2x(50-240)	8xKG43	12,8	1

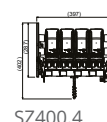

Connectors for 400 A pole fuse switches: KG43, KG43.6, KG36 and KG20

Pole fuse switches SZ41, SZ46 and SZ46.1 are equipped with Al-connectors KG43. The connectors can be replaced with Al/Cu-connectors KG36 or tin-plated Al/Cu-connector KG43.6 or Cu-connectors KG20.

Product code	GTIN	Conductor size mm ²	Conductor diameter mm	Tightening torque Nm	Weight (kg)	Pack. /pcs
KG43	6418677400254	Al 50-240	7.7-20	40	0.329	25
KG43.6	6418677412462	Al/Cu 50-240	7.7-20	44	0.32	25
KG36	6418677400223	Al 50-240 / Cu 10-95	Al 7.7-20 / Cu 3.5-12.5	44	0.34	25
KG20	6418677400186	Cu 16-185	4.5-17.5	22	0.153	50

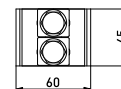
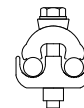

KG43



Pole fuse switch disconnectors

Marking sets for pole fuse switches

The marking set consists of an aluminium fastening bar PEM216 and plastic number plates PEM242.X. We have a wide selection of number plates, here are few examples.

Product code	GTIN	Dimensions mm	Plate no.	Weight (kg)	Pack./ pcs
PEM216	6418677400421	250x30x3	-	0.120	50
PEM242.25	6418677411830	145x60x1.5	25A	0.018	100
PEM242.400	6418677400629	145x60x1.5	400A	0.018	100
PEM241.1	6418677400445	64x64x3	1	0.007	100
PEM241.6	6418677400520	64x64x3	6	0.007	100

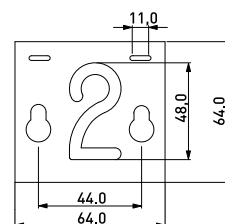

Multi-bracket PEK49

Used for the attachment of pole fuse switches to steel, concrete and wooden poles by screw or band fixing. The bracket is made of hot-dip galvanized steel.

Product code	GTIN	FOR pole fuse switches	Weight (kg)	Pack./ pcs
PEK49	6418677400414	160 A or 400 A	1.556	10

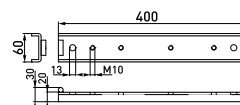

Mounting racks PEK43 and PE43.1

Used for the attachment of several 160 A and 400 A pole fuse switches to the same pole. The mounting racks are made of hot-dip galvanized steel.

Product code	GTIN	For pole fuse switches	Weight (kg)	Pack./ pcs
PEK43	6418677400391	5x160 A or 2x160 A and 2x400 A	9.005	1
PEK43.1	6418677400407	2x160 A and 2x400 A	7.4	

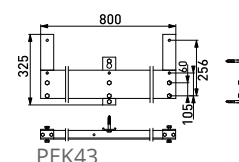

Mounting racks PEK41 and PEK42

The mounting rack is made of aluminium and used for the installations of two pole fuse switches on the same pole.

Product code	GTIN	For pole fuse switches	Weight (kg)	Pack./ pcs
PEK41	6418677400377	2x160 A	0.567	1
PEK42	6418677400384	2x400 A or 1 X 400 A and 1x160 A	0.79	1

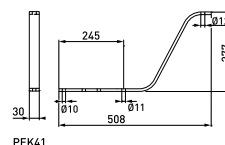

Operating rod ST33

Pole fuse switches can be operated from the ground by using the operating rod ST33.

Product code	GTIN	Length m	Weight (kg)	Pack./ pcs
ST33	6418677405532	2/1.3	1	1



Voltage indicator ST97

Used for checking the fuses of pole fuse switches, without climbing the pole and opening the fuse switch. By using operating rod, the antenna of the voltage detector is pushed into the voltage measuring opening of the fuse switch.

If the fuse holder is live, the small LED is lit. A live conductor can also be detected by touching the insulation of a phase conductor with the voltage indicator.

Product code	GTIN	Description	Weight (kg)	Pack./ pcs
ST97	6418677408670		0.319	1
ST97.1	6418677408687	with carrying case	0.4	1
ST97.2	6418677408694	for ST97	0.06	1
ST97.3	6418677408700	with buzzer	0.342	10



Direction of rotation indicator CT1 for 400 V lines

The direction of rotation of the three-phase system can be determined without peeling the conductor insulation. Safe for direct connections to live lines. Displays a missing phase, suitable for determining phase difference. Watertight construction. Carrying case included.

Product code	GTIN	Weight (kg)	Pack./ pcs
CT1	6418677408762	1.318	1



Earthing devices ST196.2 and 197.2

Earthing devices are used for temporary earthing of the low-voltage network during installation work by attaching the earthing device to the pole fuse switch. Suitable for 160 A pole fuse switches. Conductor is included. Short-circuit current 9 kA/1 s. Comes with an earthing conductor Cu 35 mm² of 3 meter and a connector.

Product code	GTIN	For pole fuse switches	Number of poles	Weight (kg)	Pack./ pcs
ST196.2	6418677417436	For SZ51, SZ152	3	2.8	1
ST197.2	6418677432705	For SZ56, SZ56.1, SZ156	4	2.8	1



ST196.2

Fixing Materials for Pole and Wall Mount

Wall mounted clamp SO125

Used for the anchoring and suspension of the 2-4-core LV ABC-cables to wooden, stone, brick or concrete walls in straight lines and angles up to 30°.

Product code	GTIN	Conductor diameter mm	Tightening torque Nm	Weight (kg)	Pack. /pcs
SO125	6418677404238	12-44	10	0.33	25

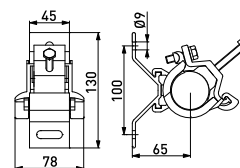

Distance nails SO70

Used for the attachment of an overhead cable or a conductor to a pole or a wall. The nails are designed so that the installed cable does not come into contact with the pole or wall surface. The plastic parts are made of heat and UV-radiation resistant materials and the metal parts are protected against corrosion. Distance from the surface 40 mm.

Product code	GTIN	Cable dia. mm	Used for	Distance from surface mm	Screw/nail mm	Weight (kg)	Pack. /pcs
SO70	6418677404863	12-47	wooden surfaces	40	body and band only	0.015	100
SO70.11	6418677404870	12-47	wooden surfaces	40	5 inch nail/137 mm	0.035	250
SO70.13	6418677404894	12-47	hard walls	40	6x110 screw, 10x50 plug	0.045	250
SO70.16	6418677414695	12-47	wooden surfaces	40	6.7x120 screw	0.045	250
SO70.17	6418677404917	12-47	hard walls	40	6.7x120 screw, 10x50 plug	0.055	250
SO70.19	6418677431272	12-47	hard walls	40	5.5x125 nail, 10x50 plug	0.05	100

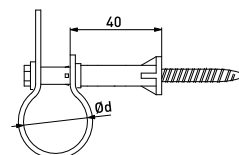

SO70



Distance nail SO71 and perforated band SO71.1

Used for the attachment of an overhead cable or a conductor to wooden surfaces. SO71 includes one perforated band SO71.1, but can also be used with two perforated bands. Distance from the surface 90 mm.

Product code	GTIN	Cable dia. mm	Used for	Distance from surface mm	Screw/nail mm	Weight (kg)	Pack. /pcs
SO71	6418677404924	12-47	wooden surfaces	80	7 inch / 175 mm	0.051	100
SO71.1	6418677404948	12-47	-	-	-	0.010	500

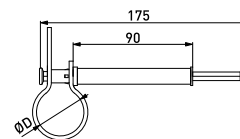

SO71



Distance nails SO76

Distance nails SO76 are used for attachment of an overhead cable or a conductor to a wooden pole or a wall. The nails are designed so that the installed cable does not come into contact with the pole or wall surface. Distance from the surface 60 mm.

Product code	GTIN	Cable dia. mm	Used For	Distance from surface mm	Screw/nail mm	Weight (kg)	Pack. /pcs
SO76	6418677446382	12-47	-	60	Body and band only	0.017	100
SO76.11	6418677446399	12-47	Wooden surfaces	60	5.5x145 nail	0.047	100
SO76.19	6418677446429	12-47	hard walls	60	5.5x145 nail, 10x50 plug	0.060	100

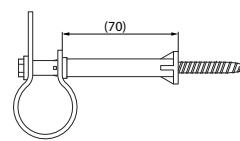

SO76



Distance nail SO277

SO277 is for the installation on facades all bundles fitted with neutral conductor as specified in standard NF C 33-040.

Product code	GTIN	Cable dia. mm	Used for	Distance from surface mm	Screw/nail mm	Weight (kg)	Pack. /pcs
SO277	6418677448461	30-48	hard walls	35	5x100 nail, 12x60 plug	0.031	100

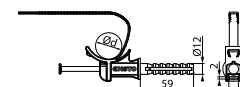



Distance nail SO277.1

SO277.1 is for the installation on wooden poles insulated bundles.

Product code	GTIN	Cable dia. mm	Used for	Distance from surface mm	Screw /nail mm	Weight (kg)	Pack. /pcs
SO277.1	6418677448478	14.8-50	wooden surfaces	35	5.1x90 nail	0.030	100

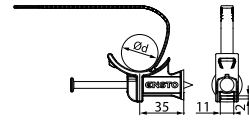

Light Pole Bracket SO279

Used with bands for pole installation and with screws for wall installation.

Product code	GTIN	SMFL KN	Weight (kg)	Pack. /pcs
SO279	6418677452246	2	0.036	50

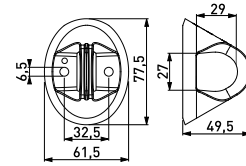

Multi-cleat SO103

For the attachment of cables or tubes to wooden surfaces or hard walls. Manufactured of weather and UV-radiation resistant thermoplastic, nails are electrical galvanized.

Product code	GTIN	Cable dia. mm	Used for	Distance from surface mm	Screw/nail mm	Weight (kg)	Pack. /pcs
SO103	6418677404023	16-25	Wooden surfaces, hard walls	0/5	50x2.5	0.01	500

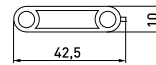
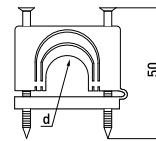

Distance clips SO79.1 and SO79.5

Used for the attachment of an overhead cable or a conductor to metal and concrete poles. Distance from surface 25 mm.

Product code	GTIN	Description	Weight (kg)	Pack. /pcs
SO79.1	6418677405006	With 1000 mm band	0.18	25
SO79.5	6418677405013	Without band	0.065	50

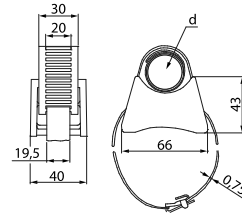

Distance nail SO42.1

Used for the attachment of an overhead cable or a conductor to a pole or a wall.

Product code	GTIN	Cable dia. mm	Used for	Distance from surface mm	Screw/nail mm	Weight (kg)	Pack. /pcs
SO42.1	6418677411762	3-13	wooden surfaces	50	6.7x160	0.035	50

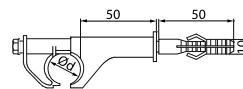

Distance clips SO72.1 and SO72.2

Used for the attachment of an underground or a service cable to a wooden or a concrete wall.

Product code	GTIN	Cable dia. mm	Used for	Distance from surface mm	Screw/nail mm	Weight (kg)	Pack. /pcs
SO72.1	6418677404979	27-32	Wooden surfaces	8	5x50	0.02	250
SO72.2	6418677404986	27-32	Hard walls	8	5x40 + plug 8x40	0.022	250

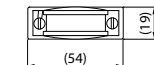
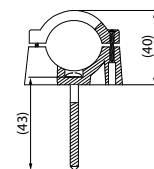

Distance clip SO75.100 for all surfaces

For the attachment underground cables to wooden poles.

Product code	GTIN	Cable dia. mm	Used for	Distance from surface mm	Weight (kg)	Pack. /pcs
SO75.100	6418677421730	45-100	All surfaces	50 mm	0.105	15/945

SO72.1



Suspension Hooks

Suspension hooks through the pole SOT15

The suspension hook is used with insulated overhead cables or service cables. The hook is made of hot dip galvanized steel.

Product code	GTIN	d	L mm	B mm	A mm	K mm	Test load Fx/kN	Test load Fy/kN	Weight (kg)	Pack. /pcs
SOT15.82	6418677410291	M12	200	120	18	60	4.8	1.5	0.42	25
SOT15.92	6418677410307	M12	240	120	18	60	4.8	1.5	0.46	25
SOT15.8	6418677410314	M16	200	120	18	70	9.6	2.4	0.8	20
SOT15.9	6418677410321	M16	240	120	18	70	9.6	2.4	0.86	20
SOT15.10	6418677410338	M16	320	120	18	70	9.6	2.4	0.99	20

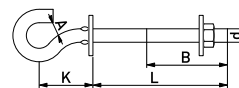

SOT15.8



Suspension hooks through the pole SOT21

Product code	GTIN	d	L mm	B mm	A mm	K mm	Test load Fx/kN	Test load Fy/kN	Weight (kg)	Pack. /pcs
SOT21.16	6418677407901	M16	200	120	20	80	11.9	2.4	0.78	20
SOT21.116	6418677407895	M16	240	120	20	80	11.9	2.4	0.84	20
SOT21.216	6418677407925	M16	320	120	20	80	11.9	2.4	0.97	20
SOT21	6418677407840	M20	200	120	20	80	14.5	4.6	1.22	20
SOT21.1	6418677410376	M20	240	120	20	80	14.5	4.6	1.32	20
SOT21.2	6418677407918	M20	320	120	20	80	14.5	4.6	1.51	20
SOT21.3	6418677410383	M20	350	120	20	80	14.5	4.6	1.58	20

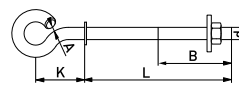

SOT21.1



Suspension hooks through the pole SOT21.0

Product code	GTIN	d	L mm	B mm	A mm	K mm	Test load Fx/kN	Test load Fy/kN	Weight (kg)	Pack. /pcs
SOT21.0	6418677407857	M20	200	120	20	80	14.5	4.6	1.22	20
SOT21.01	6418677407864	M20	240	120	20	80	14.5	4.6	1.39	20
SOT21.02	6418677407871	M20	320	120	20	80	14.5	4.6	1.51	20

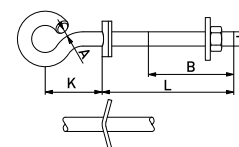

SOT21.0



Suspension hooks through the pole SOT101

Product code	GTIN	d	L mm	B mm	A mm	K mm	Test load Fx/kN	Test load Fy/kN	Weight (kg)	Pack. /pcs
SOT101.1	6418677410277	M20	250	110	24	70	30.6	6.7	1.7	10
SOT101.2	6418677410284	M20	310	140	24	70	30.6	6.7	1.8	10

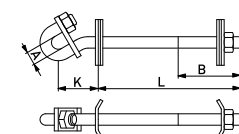

SOT101.1



Double arming bolts SOT4

Product code	GTIN	d	L mm	B mm	C mm	R mm	E mm	Weight (kg)	Pack. /pcs
SOT4.8	6418677410079	M16	240	120	25	100	60	0.5	20
SOT4.9	6418677407994	M16	280	120	25	100	60	0.61	20
SOT4.10	6418677407956	M16	360	120	25	100	60	0.69	20
SOT4.5	6418677407963	M20	240	120	25	100	60	0.6	20
SOT4.6	6418677407970	M20	280	120	25	100	60	0.72	20
SOT4.7	6418677407987	M20	360	120	25	100	60	0.87	20

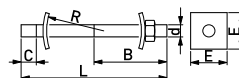

SOT4



Nut hooks PD2.3 and PD2.2

Used when a parallel line is required. Also used as Tension hooks.

Product code	GTIN	d	D mm	L mm	A mm	Test load Fx/kN	Test load Fy/kN	Weight (kg)	Pack. /pcs
PD2.3	6418677401060	M16	38	76	20	15.4	2	0.383	25
PD2.2	6418677401053	M20	38	76	20	15.5	4	0.55	25

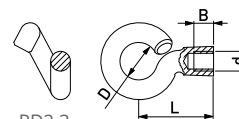

PD2.3





Nut hooks for external angles PD3.3, PD3.2 and SOT74

Product code	GTIN	d	D mm	L mm	A mm	Test load Fx/kN	Test load Fy/kN	Weight (kg)	Pack. /pcs
PD3.3	6418677406355	M16	16	206	20	9.7	6.2	1.23	10
PD3.2	6418677406348	M20	20	200	20	13.3	8.6	1.9	10
SOT74	6418677408021	M24	25	290	24	24.6	19.5	3.4	10

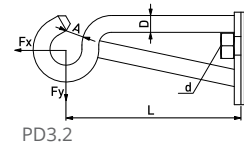

Screw hooks with wood thread SOT1.1, SOT16.10 and SOT16.12

Product code	GTIN	d	L mm	B mm	A mm	Test load Fx/kN	Test load Fy/kN	Weight (kg)	Pack. /pcs
SOT16.12	6418677410062	Ø12	165	85	16	5.3	4.1	0.24	50
SOT16.10	6418677407833	Ø16	170	90	16	8.8	6.6	0.44	30
SOT1.1	6418677407826	Ø20	165	85	18	16.6	12.9	0.73	20

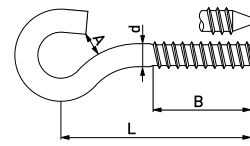

Band hooks SOT29 and SOT39

Used for steel and concrete poles. The band hooks are mounted on poles by using band and buckles.

Product code	GTIN	D mm	A mm	K mm	H mm	C mm	SMFL Fx/kN	SMFL Fy/kN	Weight (kg)	Pack. /pcs
SOT29	6418677413544	Ø16	18	85	150	45	17.8	12.5	0.71	25
SOT39	6418677413551	Ø20	18	91	150	50	27.7	17.7	0.74	25

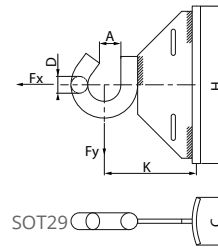

Universal hooks SOT76 and plate hooks SOT28

Plate hook SOT28 is for wall installations. Universal hook SOT76 is used with bands for pole and with screws for wall installations:

Delivery includes:

SOT28, Hook without any screws, SOT28.1, Hook and six slotted round head wood screws, 6.7x160/60 DIN 96, Soft wall.

SOT28.2, Hook and six hexagon head wood screws 6x50 DIN 571 and six plastic plugs 10x50, Concrete.

SOT28.3, Hook and six hexagon head wood screws 6x50 DIN 571, Wood.

SOT76, Hook without any screws.

SOT76.2, Hook and six hexagon head wood screws 6x50 DIN 571 and six plastic plugs 10x50.

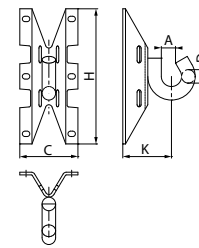

Product code	GTIN	D mm	A mm	K mm	H mm	C mm	SMFL Fx/kN	SMFL Fy/kN	Weight (kg)	Pack. /pcs
SOT28	6418677413506	Ø16	18	67	200	96	17.4	13.3	0.67	25
SOT28.1	6418677413513	Ø16	18	67	200	96	17.4	13.3	0.84	25
SOT28.2	6418677413520	Ø16	18	67	200	96	17.4	13.3	0.74	25
SOT76	6418677413582	Ø16	18	67	200	96	16.6	12.6	0.61	25
SOT76.2	6418677419287	Ø16	18	67	200	96	16.6	12.6	0.65	25

SOT76

Band COT37 and buckle COT36 for band hooks

Installation with tightening tool CT42.

Product code	GTIN	Description	Weight (kg)	Pack. /pcs
COT37	6418677412196	19 mm x 0.75 mm x 25 m, AISI301	2.875	25
COT36	6418677412189	for band COT37	0.013	100



COT37



COT36

Bracket for tension clamp SO253 and bracket for suspension clamp SO260.2

SO253 is a bracket for anchoring. Made of corrosion resistant aluminium alloy. The bracket is easy to install with screws as no special tools are needed. SO260.2 is a bracket for suspension clamp.

Product code	GTIN	SMFL kN	Weight (kg)	Pack. /pcs
SO253	6418677418907	22	0.11	25
SO260.2	6418677419065	15.5	0.21	50

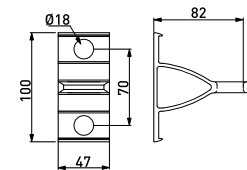

SO253



Stay Wire Accessories and Pole Base Reinforcers

Stay wire attachment fittings SH35 and SH187

Used for the attachment of stay wires to wooden poles. The plates are employed to prevent the stay wire from cutting into the pole.

Product code	GTIN	Stay wire mm ²	Rope diameter mm	A mm	B mm	E mm	Weight (kg)	Pack. /pcs
SH35	6418677402203	25	6.36	55	60	9	0.079	100
SH187	6418677402128	25-68	6.36-10.60	100	95	11	0.2	50

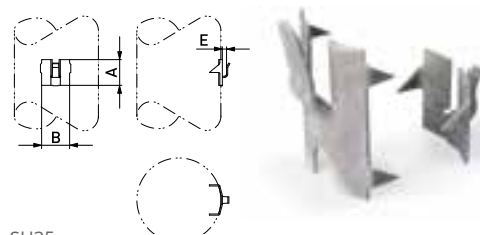

SH35

Stay wire clamps CHLK25 and SH517

Used for the attachment of the upper end of the stay wire to the pole.

Product code	GTIN	Stay wire mm ²	Rope diameter mm	A mm	B mm	C mm	R mm	SMFL kN	Pack. /pcs
CHLK25	6418677410772	25	6.36	49	49	35	4.5	32	50
SH517	6418677414657	52-68	9.2-10.6	60	60	48	6	95	25

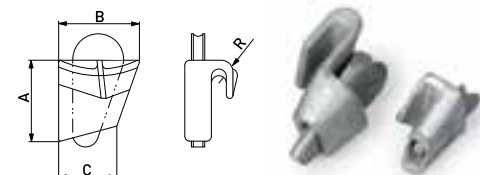

CHLK25

Stay wire clamps CHK25.1 and SH49

Used for the attachment of the lower end of stay wire to anchor rod or other similar foundation accessories.

Product code	GTIN	Stay wire mm ²	Rope diameter mm	A mm	B mm	d	L mm	SMFL kN	Weight (kg)	Pack. /pcs
CHK25.1	6418677406294	25	6.36-6.4	40	200	M12	300	32	0.715	20
SH49	6418677430022	25-68	6.36-10.6					88 (68 mm ²)	1.57	25

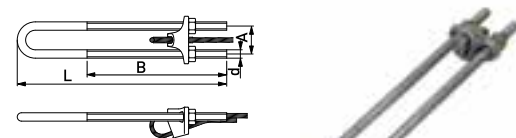

CHK25.1

Stay wire sets SHS25P

The pre-assembled stay wire sets result in better logistics, smaller storage quantities and easier handling. The sets include a stay wire, a wedge clamp, black and yellow stay wire marks, fixing plates and a stay wire clamp or a stay iron with thimble.

Product code	GTIN	Description	Weight (kg)	Pack. /pcs
SHS25P.110L	6418677407635	Upper end clamp, length 11.0 m	4.3	1
SHS25P.135L	6418677407659	Upper end clamp, length 13.5 m	5	1
SHS25P.110R	6418677407642	Upper end iron, length 11.0 m	4.9	1
SHS25P.135R	6418677407666	Upper end iron, length 13.5 m	5.6	1



SHS25P.110L

Stay wire mark sets SH25, SH144 and SH45

Used for the marking of all stay wires. In the case of a previously installed stay wire, marks can be added by simply splitting the plastic marks and pressing them around the wire. The combination of 6 yellow and 6 black marks guarantees good visibility. The material is weather and UV-radiation resistant plastic.

Product code	GTIN	Stay wire mm ²	Inside diameter mm	Total length mm	Weight (kg)	Pack. /pcs
SH25	6418677402173	Fe 25	15	12x210=2520	0.19	25
SH144	6418677402081	Fe 67	25	12x210=2520	0.407	10
SH45	6418677402210	Fe 185	35	12x210=2520	0.54	5

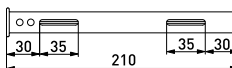

SH25



Pole hats SP21, SP20, SP18 and SP19

Used for the protection of the tops of wooden poles. Fixed with hot-dip galvanized nails (provided in the package). Made of weather and UV-radiation resistant plastic.

Product code	GTIN	Description	Weight (kg)	Pack. /pcs
SP20	6418677405242	Diameter 170 mm	0.054	100
SP18	6418677405228	Diameter 190 mm	0.062	100
SP19	6418677405235	Diameter 230 mm	0.082	100
SP21	6418677452208	Diameter 270 mm	0.106	20

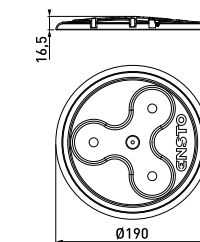

SP18





Pole base reinforcing sets SH0, SH1, SH2 and SH3

To reinforce wooden pole bases, weakened by decay or damage at ground level. Reinforcing sets are an economical, easy and safe way to increase the lifetime of wooden poles.

Product code	GTIN	D mm	L mm	BOLTS	Pole diam. mm	Weight (kg)	Pack./ pcs
SH0	6418677406782	160	1500	M12x120	130-170	19.5	1
SH1	6418677406799	200	1500	M12x120	170-210	24.0	1
SH2	6418677407123	250	1500	M12x120	210-260	39.0	1
SH3	6418677414466	300	1500	M12x120	260-300	50.0	1

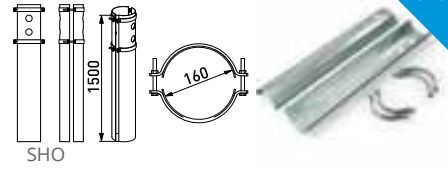

Anvil ST53

Anvil is used in driving pole base reinforcers into the ground.

Product code	GTIN	Weight (kg)	Pack. / pcs
ST53	6418677408649	21.0	1



Tightener ST55

It is easy to pull the reinforcer channels against the pole with the tightener. While ST55 holds the channels in place, reinforcer tying bands can be readily put in their place around the reinforcer channels.

Product code	GTIN	Weight (kg)	Pack. / pcs
ST55	6418677408663	2.9	1



Lamp post fixtures

Branching connectors and connector sets

KE connectors and SV connector sets are used for connecting and branching aluminium and copper cables in lamp posts or in cable cabinets. Ensto connectors are tinned to suit for both aluminium and copper conductors (4 or 6 conductors). The connectors can be used as L, N, PE or PEN connectors.

Product code	GTIN	Description	Weight (kg)	Pack. /pcs
Branching connectors				
KE10.1	6418677400049	Al 4x10-35 mm ² / Cu 1.5-25 mm ²	0.044	50
KE10.1N	6438100330705	Al 4x10-35 mm ² / Cu 1.5-25 mm ²	0.04	50
KE10.3	6418677400063	Al 6x10-35 mm ² / Cu 1.5-25 mm ²	0.065	50
KE10.504	6418677400087	Al 4x10-50 mm ² / Cu 2.5-35 mm ²	0.058	50
KE10.504N	6418677455421	Al 4x10-50 mm ² / Cu 2.5-35 mm ²	0.045	50
KE10.506	6418677400094	Al 6x10-50 mm ² / Cu 2.5-35 mm ²	0.07	50
Cover for KE10.504(N)				
PMR2680.3	6438100321352	3 pcs set for KE10.504(N)	0.022	30
PMR2680.4	6438100308384	4 pcs set for KE10.504(N)	0.022	30
Branching connector sets				
SV15	6418677405624	3xKE10.1 and 1xKE10.3 (10-35Al/1.5-25Cu)	0.27	10
SV15.5	6418677405716	4xKE10.1 and 1xKE10.3 (10-35Al/1.5-25Cu)	0.304	10
SV50	6418677405808	3xKE10.504 and 1xKE10.506 (10-50Al/2.5-35Cu)	0.315	10

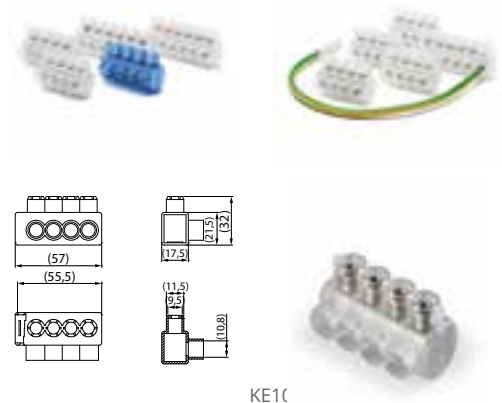

KE10



KE10.3

KE10.504

KE10.504N

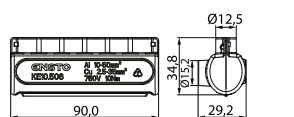

KE10.506



PMR2680



SV15

Fuse bases

Ensto's new LFB16-R is a small, robust and space saving fuse base for street lighting. It will not only save space, but also installation effort.

Product code	GTIN	Description	Conductor size mm ²	Weight (kg)	Pack. /pcs
LFB16-R	6438100320928	Empty fuse base max 16A	4	0.283	10
LFB16.1-R	6438100320935	Empty fuse base max 16A	10	0.283	10
LFB16-06A-R	6438100320904	Fuse base, 6A fuse	4	0.283	10
LFB16-10A-R	6438100320911	Fuse base, 10A fuse	4	0.283	10
LFB16.1-06A-R	6438100320966	Fuse base, 6A fuse	10	0.283	10
LFB16.1-10A-R	6438100320973	Fuse base, 10A fuse	10	0.283	10

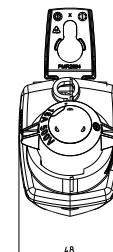



Lamp post fixtures

Ensto's branching KE connectors are quick and handy to install. The body is made of tin plated aluminium and the screws are nickel plated brass. The connector cover is made of transparent polycarbonate plastic in order to ease and speed up the installation.

Product code	GTIN	Description	Conductor size mm ²	KE connector conductor sizes mm ²	Weight (kg)	Pack. /pcs
LCK4-16-06A	6438100309176	LFB16-06A-R + 3xKE10.1 + 1xKE10.3	4	Al 10-35 / Cu 1.5-25	0.57	10
LCK5-16-06A	6438100309183	LFB16-06A-R + 4xKE10.1 + 1xKE10.3	4	Al 10-35 / Cu 1.5-25	0.57	10
LCK4-16-10A	6438100309190	LFB16-10A-R + 3xKE10.1 + 1xKE10.3	4	Al 10-35 / Cu 1.5-25	0.57	10
LCK5-16-10A	6438100309206	LFB16-10A-R + 4xKE10.1 + 1xKE10.3	4	Al 10-35 / Cu 1.5-25	0.57	10
LCK4-06.1-06A	6438100327972	LFB16.1-06A-R + 3xKE10.1 + 1xKE10.3	10	Al 10-35 / Cu 1.5-25	0.57	10
LCK5-06.1-06A	6438100327958	LFB16.1-06A-R + 4xKE10.1 + 1xKE10.3	10	Al 10-35 / Cu 1.5-25	0.57	10
LCK4-10.1-10A	6438100327989	LFB16.1-10A-R + 3xKE10.1 + 1xKE10.3	10	Al 10-35 / Cu 1.5-25	0.57	10
LCK5-10.1-10A	6438100327965	LFB16.1-10A-R + 4xKE10.1 + 1xKE10.3	10	Al 10-35 / Cu 1.5-25	0.57	10



Lamp post cabinets

SK160 cabinets are installed on wooden poles. The cabinets can be either zinc coated or in case of the /M after type refers to UV resistant RAL 6013 (dark green) painted cabinets. Cabinets can be empty, including SVV fuse base set, or only branching connector set.

Product code	GTIN	Description	Weight (kg)	Pack. /pcs
Zinc coated cabinets				
SK160	6418677403378	Zinc coated	9.5	1
SK160.1	6418677403385	Zinc coated, SV15.11	10.0	1
SK160.2	6418677403392	Zinc coated, SV15.11 + SVV1.10	10.3	1
Painted cabinets				
SK160.1/M	6418677406119	Zinc coated, painted, SV15.11	10.0	1
SK160.2/M	6418677403408	Zinc coated, painted, SV15.11 + SVV1.10	10.3	1
SK160/M	6418677403415	Zinc coated, painted	9.5	1

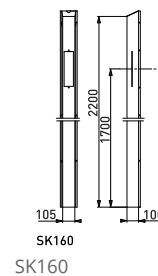

Covered fuse bases for overhead lines

Covered SV29 fuse bases, with or without connectors for lamp post installations on overhead lines.

Product code	GTIN	Connectors included	Fuse max A	Weight (kg)	Pack. /pcs
Covered fuse bases without connectors					
SV29.25	6418677432873	-	25	0.23	10
SV29.63	6418677432880	-	63	0.384	10
Covered fuse bases including connectors					
SV29.2511	6418677432835	SL11.11	25	0.321	10
SV29.2522	6418677432859	SLIP22.1	25	3.69	10
SV29.2552	6438100318000	SLIW52	25	0.287	10
SV29.6311	6418677432842	SL11.11	63	0.475	10
SV29.6322	6418677432866	SLIP22.1	63	0.468	10
SV29.6352	6438100318024	SLIW52	63	0.468	10



A blue diamond-shaped logo containing the word "MEDIUM" in white capital letters above a white stylized waveform symbol.

MEDIUM

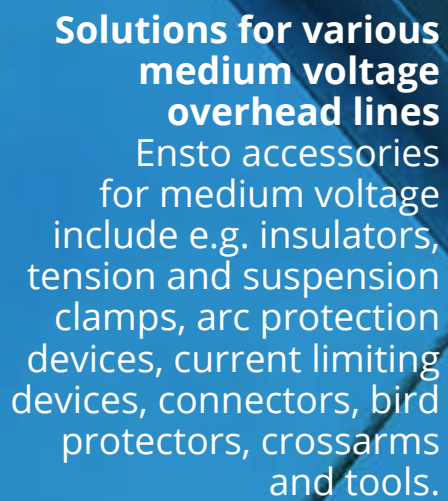
A white text block on a blue background, describing Ensto accessories for medium voltage overhead lines. A white arrow points from the text towards the right.

**Solutions for various
medium voltage
overhead lines**
Ensto accessories
for medium voltage
include e.g. insulators,
tension and suspension
clamps, arc protection
devices, current limiting
devices, connectors, bird
protectors, crossarms
and tools.

A photograph of a utility pole under construction. The pole is made of wood and has several metal crossarms and insulators attached. A red wire is visible at the top left, and a yellow wire is visible at the top right. The background is a clear blue sky.

Covered Conductor line
under construction.

Covered Conductor Solution

11-36kV



Plastic covered conductors without metal sheaths were developed to improve reliability of the distribution and transfer of electricity. Several years in use have proven the covered conductor system to be extremely functional and reliable. Interruptions and faults caused by snow, ice or storms have diminished remarkably.

Using the Covered Conductor solution offers also considerable space savings as the space required is approximately 40 % less than that of a standard bare line.

This means e.g. narrow line corridors and space savings in substations. Parallel line structure enables more space savings.

Ensto accessories for medium voltage covered conductors are tested according to the EN 50397-2 standard. Compared to earlier national standards, EN 50397-2 is substantially more demanding and covers the accessories designed for covered conductors more extensively. This adds reliability for the covered conductor system.

➤ The Ensto covered conductor accessories cover 6-24 kV and 36 kV lines and can be found on pages 60-75.

Full Covered Conductor Solution



Covered conductors were developed to improve reliability of the distribution of electricity. Time has assured the Covered Conductor solution to be extremely functional and reliable. Faults caused by snow, ice or storms have decreased remarkably. Full Covered Conductor Solution provides even more complete protection for the line.

Covered Conductor Solution (CC) allows space savings e.g. 40% narrower clearances for line corridors through forested areas, compared to a standard bare line. With parallel line structure, the space saving is even bigger. Ensto accessories for medium voltage Covered Conductor Solutions are tested according to the EN 50397-2 standard which, compared to earlier national standards, is substantially more demanding and covers the accessories designed for such solutions more extensively. This brings a whole lot of reliability for the

Covered Conductor Solution.

Benefits of FCCS

Full Covered Conductor Solution (FCC) provides even more complete protection for the line compared to traditional Covered Conductor Solution.

In addition for the covering of the conductors, other live parts of the line have been covered also such as insulators, support- and tension clamps, connectors, etc. This has been done to acquire even more protection from wildlife, such as birds and squirrels, and to pre-

vent interruptions in the distribution of electricity.

Choosing a Full Covered Conductor solution with Ensto accessories is guaranteed to pay for itself in the form of fewer faults, lower maintenance costs, and higher-quality electricity.

Ensto's accessories to Full Covered Conductor lines are electrically and mechanically designed for the best performance and safety. Accessories for medium voltage Full Covered Conductor lines include insulators, tension and suspension clamps, arc protection de-



vices, current limiters, connectors, bird protectors and crossarms.

Requirements with Covered Conductors

Some additional requirements have been set for Covered Conductors, compared to traditional bare conductor construction:

- Conductors must be handled with care.
- Only accessories designed and approved for the conductor shall be used.
- Arc Protection devices must be used on lines vulnerable to overvoltage.
- Substations must have tripping earth-fault protection devices and alarming secondary devices.

Arc Protection

Overvoltage is induced on the line usually when lightning strikes on an over-

head line or near it. The magnitude of the overvoltage is approximately the same in all phases and may rise to several hundred kilovolts between a phase conductor and earth.

The overvoltage travels along the line to the nearest pole and discharges there by igniting an arc between the crossarm and the conductors. After the overvoltage has discharged a power frequency short-circuit current start to flow through ionized air, resulting in a power arc between the phases.

Power arc magnitude is normally several kilo amperes. Power arc can move freely along an ordinary bare conductor line towards the load, but in the covered conductor line the covering forms an obstacle. When an arc ignites, it burns a small hole in the covering and keeps burning until the conductor is damaged or burned through.

Circuit breakers cannot respond quickly enough. In order to prevent damage a

covered conductor must be protected by installing arc protection devices to appropriate locations. These offer the power arc a safe discharge route without damaging the conductor.

Placing of the Arc Protection

An Arc Protection device is used to protect the conductors as well as other network components. In this way, it is possible to achieve disruption-free distribution of electricity, a major benefit to the consumer. Arc protection devices must be installed in places in which overvoltage is likely to occur, e.g. fields and hills. Furthermore, protection is required in frequently used areas; for example, buildings, yards, their immediate vicinity, traffic routes and sports fields. The protection chosen also depends on the network's short-circuit values.



Bare Conductor System



Ensto's assortment for the conventional Bare Conductor Line Networks covers most common conductors.

The comprehensive range of the accessories provides a simple and economic system for line erection. The products comply with the most commonly used European standards. Our accessories are designed in co-operation with power supply companies. They are easy to install and have a long service life in extremely hard climatic conditions.

➤ Ensto accessories for Bare Conductor System are presented on pages 76-82.

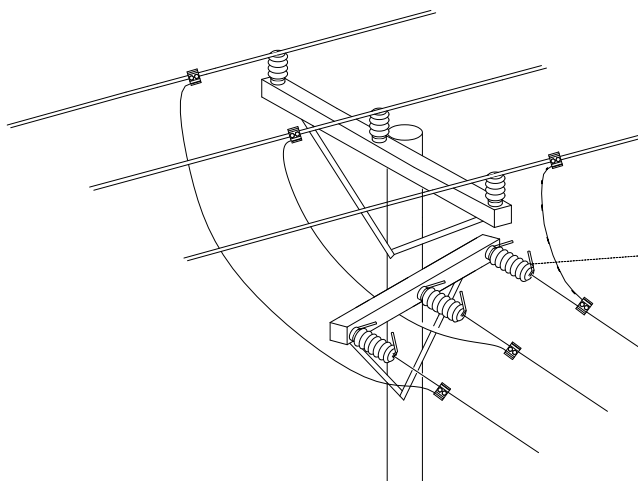

Universal Cable System 12-36 kV



Universal cables can be installed in demanding conditions underground, in water or in air. Ensto has designed a range of special accessories for universal cable systems.

Our long experience of demanding circumstances has helped us to develop reliable and safe accessories.

However, because there are so many different manufacturers of universal cables the suitability of the accessories should always be confirmed by the cable manufacturer.

Also Ensto Underground Solutions offer a wide range of strong and reliable joints and terminations.

There is a separate Ensto Underground brochure, which can be found in our web pages www.ensto.com - Brochures.



Ensto Crossarms and Pole Accessories for Medium Voltage Systems



Ensto has a wide range of cross-arms and pole accessories for medium voltage lines. Our crossarms have been in use in Nordic countries for decades.

Ensto´s crossarms cover most typical products for:

- PAS system with pin insulators
- BLL/BLX system with line post insulators
- Bare MV systems.

They are designed for installation on wooden, steel or concrete poles. Ensto´s crossarms are made of corrosion resistant, hot-dip galvanized steel. The construction suits for straight lines, angles up to 90 degrees and terminal poles.

In addition to standard models Ensto also supplies 24 and 36 kV special crossarms. We also offer tailor made crossarms according to special requirements of our customers. Ensto also provides a very vast pole accessory portfolio.

The offering

- Finished stay wire sets
- Eye-bolts and stay anchors
- Stay anchors for rock installations
- Pole braces for wooden poles
- Hooks
- Pole reinforcers for wooden poles
- Pole foundations for marsh poles.

Network Automation

Control for you and your assets whenever and wherever



Network Automation means more flexibility and powerful tools for recovery from a fault. It also plays an essential role in smart grids, which allow customers to participate actively in the electricity market through a two-way flow of energy and information.

Ensto's network automation products play a key role in rapid post-fault recovery and improved reconfiguration of the grid. Our smart pole-mounted reclosers detect faults as they occur and then attempt to restore the line to its normal status automatically.

Furthermore, our range of solutions covers load-break switches with remote control for medium voltage overhead lines, pole-mounted circuit-breakers for the protection of low voltage overhead lines, and distribution panels and

fault-detectors for use in underground cable networks.

Expertise in Automation and Remote Control Equipment

Ensto Novexia's solutions are widely recognized especially in France and in other French-speaking areas. Ensto Novexia has an office and factory in France's Villefranche-sur-Saône and a factory in Bagnères-de-Bigorre. In France, Ensto is a supplier to ERDF, independent utilities, and installers.

The company is also present in other parts of Europe, Africa, Asia, and North and South America.

The offering

- Automatic reclosers
- Load-break switches with air break technologies using glass, synthetic, or porcelain insulators
- SF6 break technology
- Vacuum break technology with solid insulation.



Ensto surge arresters

The best solutions to customer's expectations



Ensto surge arresters are designed and manufactured to the highest quality standards and our surge arresters provide total control of residual voltage based on insulation coordination rules, thus considerably improving the level of protection.

Surge arresters protect the conductor as well as other network components in case of atmospheric, switching or power frequency overvoltages. They are mostly used with pole transformers and terminal poles of underground cables. Ensto's SGA surge arresters complete our solutions designed for fault free distribution of electricity. The surge arresters have been developed to endure the vast temperature variations that are common in the Nordic countries and they are designed and type tested according to IEC60099-4:2004 standard.

Ensto's range of surge arresters ensures years of maintenance-free service in the following fields:

- ▶ Overvoltage protection for HV and MV networks
- ▶ Overvoltage protection for railway networks either in direct or alternating current
- ▶ Overvoltage protection for cable sheathes
- ▶ Voltage limitation for non-earthed metal structures

Ensto has been selling its own polymer housed metal oxide surge arresters for more than 25 years under VARISIL™ trademark. VARISIL™ surge arresters can capitalize on a long and proven field experience. In particular, they have demonstrated their ability to operate durably even in the harshest environmental conditions. More than 5 million VARISIL™ surge arresters are now in service all over the world.

▶ Read more on page 68.

Products

Installing Connectors

For covered conductors, the insulation piercing connectors SLW25.2 and arc protection connectors SEW20, SEW20.1, SEW20.2 or SEW20.3 as well as corresponding SEW21 series are recommended. If the conductor is stripped, it is possible to use SL4.25 or SL8.21 connectors, which can be protected by using plastic insulation covers SP15 or SP16.

When installing connectors, the main rule is that the branch connector should always be located between the arc protection connector and crossarm. For this reason, the arc protection connectors must be installed at an adequate distance from the crossarm so that the connection can be made properly.

► Read more on page 63.



Tensioning of the Conductors

Conductors are tensioned by evenly tensioning each conductor. The sag and tension tables and recommendations of conductor manufacturer should be utilized.



Tying Conductors

Conductors can be tied to the top or neck of an insulator with helical ties or with aluminium wire. When using pre-tensioned helical ties, e.g. CO35, CO70, CO120, SO115 series or SO216 series, two ties are installed for each conductor. Only 25 mm² wire may be used for connecting arc protection connectors to insulator neck.

Earth parking device

The SEW30 is used for temporary earthing for Medium Voltage Covered Conductors (MV CC). The connector is watertight by silicone greased teeth. The nominal insulation thickness of the conductor can be between 2.3-4.0 mm.



Medium Voltage Overhead Line Solutions

Covered Conductor Solution

Pin insulator SDI37

SDI37 is used with bare wires or covered conductors. Suitable for installation on pin SOT24 (SFS 4385). The plastic sleeve in the top-groove of the insulator enables pulling of conductor without using pulleys. The conductor can be tied to the top-groove or to the neck. In angles, always tie to the neck. Creepage distance 325 mm. Neck diameter 85 mm.

Product code	GTIN	Highest system voltage kV	Breaking load kN	Insulator pin	Weight (kg)	Pack. /pcs
SDI37	6418677408731	24	12.5	SOT24	3.8	3

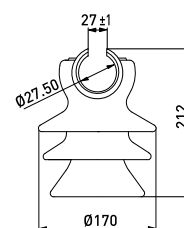

Pin insulator SDI30

SDI30 is used with bare wires or covered conductors. Suitable for installation on pin SOT24 (SFS 4385). The conductor can be tied to the top-groove or to the neck. In angles, always tie to the neck. Creepage distance 325 mm. Neck diameter 85 mm.

Product code	GTIN	Highest system voltage kV	Breaking load kN	Insulator pin	Weight (kg)	Pack. /pcs
SDI30	6418677408748	24	12.5	SOT24	3.37	3

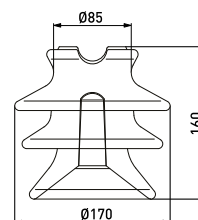

Stay insulator SDI4.5

Porcelain stay insulator is suitable for installation in stay wires up to 52 mm². Conforms with standard SFS 3741. Creepage distance is 110 mm.

Product code	GTIN	Highest system voltage kV	Max continuous load kN	SMFL kN	Weight (kg)	Pack. /pcs
SDI4.5	6418677418556	24	35	120	2.15	6

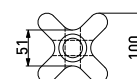
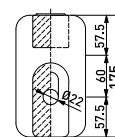

Composite stay insulators SDI70.24

SDI70.24 insulator has high mechanical and electrical capacity combined with light weight. The insulating section is made of glass fibre impregnated with UV stabilized resin and twice covered silicon rubber. The end thimble is made of aluminium and dimensioned for minimum 52 mm eyelet. SDI70.24 is suitable for installation on stay wires up to Fe52 and is tested according to IEC 60383. Creepage distance 160 mm.

Product code	GTIN	Highest system voltage kV	Max continuous load kN	SMFL kN	Weight (kg)	Pack. /pcs
SDI70.24	6418677401787	24	35	180	0.8	15

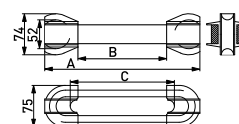

Composite insulators SDI90 series

SDI90.x composite insulators are the next step on Ensto's composite insulator series. SDI90.x insulators fulfill the requirements of IEC 61109. The sheds of the insulators are made of highly hydrophobic silicon rubber. The core is made of corrosion resistant fiber glass rod and the end fittings are made of hot-dip galvanized steel. Tension insulators SDI90.15x are meant to be used on 10 kV up to 24 kV depending on pollution class requirements. SDI90.28x are meant to be used on 24 kV up to 36 kV. Creepage distance of SDI90.15x is 391 mm and creepage distance of SDI90.28x is 613 mm.

Product code	GTIN	End fittings	Highest system voltage kV	Weight (kg)	Pack. /pcs
SDI90.150	6418677422669	eye / eye	24	0.995	3
SDI90.280	6418677422768	eye / eye	36	1.08	3
SDI90.282	6418677422782	socket / eye	36	1.3	3
SDI90.283	6418677422799	ball / socket	36	1.1	3
SDI90.284	6418677422805	clevis / tongue	36	1.3	3
SDI90.285	6418677422812	clevis / ball	36	1.2	3
SDI90.288	6418677422843	socket / tongue	36	1.3	3



SDI90.150

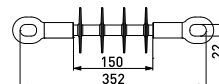

SDI90.280

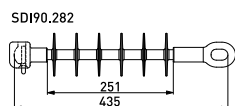
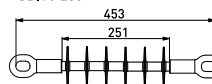

SDI90.283

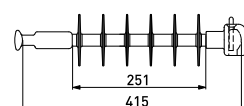

SDI90.284

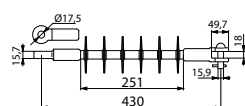

SDI90.285

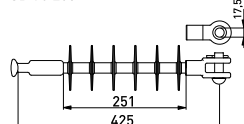

SDI90.288

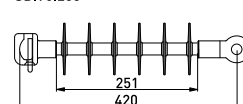

Composite line post insulators SDI82 and SDI84

Ensto's new SDI82 and SDI84 line post insulators are attached to the crossarm with bolts included in the package. Line post insulators fulfill the requirements of IEC 61952:2008, IEC 60060-1:2010. Coating is made of two-component silicone, that gives the insulator excellent dielectric strength and makes it resistant to UV radiation and harsh weather conditions. The upper fitting In order to reduce the concentration of electric field around the insulator upper fitting, it is made of insulating plastic material (PA6-GF30). Because Ensto's new composite line post insulators cause no partial discharges, the RF disturbances are eliminated.

Product code	GTIN	SMFL kN	Creepage distance mm	Dry lightning impulse withstand voltage kV	Wet power frequency withstand voltage kV	Weight (kg)	Pack. /pcs
With M20 bolt							
SDI82.1M20	6438100316013	12.5	561	156	72	2.56	1
SDI84.1M20	6438100316037	12.5	1168	181	92	2.96	1
With M24 bolt							
SDI84.1M24	6438100316044	12.5	1168	181	92	2.96	1

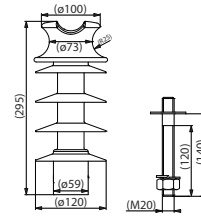

SDI82



SDI82.1M20

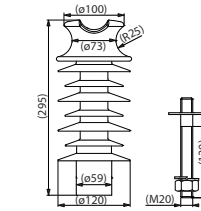

SDI84

Composite tension insulator SDI95.1

SDI95.1 composite tension insulator is used for bare or covered MV overhead lines. Insulators body is made from composite (silicone + glass fibre) and the end fittings are hot dip galvanized steel.

Product code	GTIN	SMFL kN	Creepage distance mm	Dry lightning impulse withstand voltage kV	Wet power frequency withstand voltage kV	Weight (kg)	Pack. /pcs
SDI95.1	6438100316655	80	1120	210	110	1.4	3

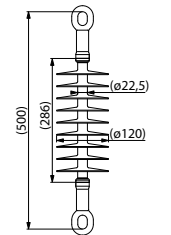

Power arc device SDI27.1

Power arc device SDI27.1 is used with SDI90.x composite insulators on angle poles with suspension clamp SO181.5 and on tension poles with tension clamps SO235 or SO236. The package includes arching horns and 95 mm² conductor with cable lugs. Spark gap is adjusted to 100-150 mm on 24-36 kV.

Product code	GTIN	Weight (kg)	Pack. /pcs
SDI27.1	6418677419133	0.83	9

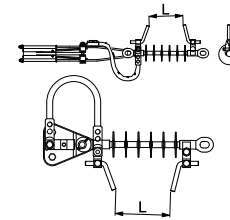

Power arc device SDI10.2

Used as arc protection with tension insulator type SDI90.x on covered conductor lines. SDI10.2 includes two horns, which are fixed to the metal parts of the tension insulator so that the peaks are towards each other and the distance between the peaks is adjustable.

Product code	GTIN	Weight (kg)	Pack. /pcs
SDI10.2	6418677410673	0.58	15

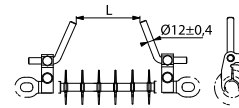

Power arc devices SDI20.3 and SDI20.2

Used on straight line cross arms for making spark gap protection. The set includes one arc protection device SE20.1 and one arc horn. The spark gap is adjustable. SDI20.3 is for horizontal pin insulator crossarm. SDI20.2 is for linepost insulator crossarm.

Product code	GTIN	Crossarm	Weight (kg)	Pack. /pcs
SDI20.3	6418677401534	Horizontal	1.6	9
SDI20.2	6418677418600	Horizontal	1.25	12

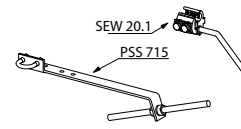

SDI20.3

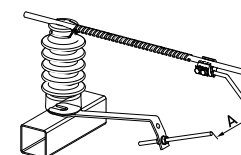

SDI20.2



Power arc device SDI25

Arc protection device for covered conductors with line post insulators. The spark gap is adjustable. The distance between the spark gap is 100 - 150 mm at 24 kV.

Product code	GTIN	Tightening torque Nm	Weight (kg)	Pack. /pcs
SDI25	6418677401541	40	1.6	3

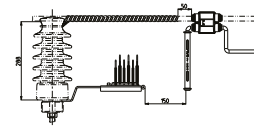

SDI251



Power arc device SDI24 and SDI29

Arc protection device for covered conductors with line post insulators. The spark gap is adjustable. Short circuit current: Arc test 10 kA / 1 s

Product code	GTIN	For conductor mm ²	Conductor diameter mm	Tightening torque Nm	Weight (kg)	Pack. /pcs
SDI24	6438100319403	CC 50-157	90-250	35±2	1.96	3
SDI29	6438100319410	CC 150-241	90-250	35	1.96	3

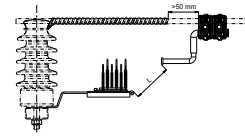

SDI24



Suspension clamp SO181.6S

Suspension clamp with pulley for covered conductors PAS/BLL AlMgSi. The clamp also functions as an installation pulley thereby completely eliminating the need for separate pulleys. Conductor joints with diameter under 30 mm can be pulled through the suspension clamp.

Product code	GTIN	For conductor mm ²	Conductor diameter mm	Tightening torque Nm	Weight (kg)	Pack. /pcs
SO181.6S	6438100324841	PAS/BLL 50-157 AlMgSi	12.7-22.3	40	1.224	3

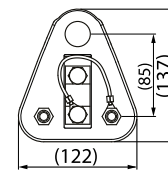

SO181.6S



Suspension clamp SO183S

Suitable for covered conductors and angles up to 90°. The clamp also functions as an installation pulley thereby completely eliminating the need for separate pulleys.

Product code	GTIN	For conductor mm ²	Conductor diameter mm	Tightening torque Nm	Weight (kg)	Pack. /pcs
SO183S	6438100332112	MV CC 120-241	18.0 ... 30.0	30	2	3

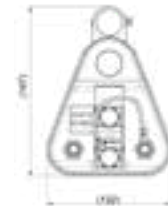

SO183S



Waterproof tension clamps SO255S and SO255.2S

For dead-ending covered conductors. The clamp is very easy to install compared with the other clamps on the market as there is no need to peel the conductor. The insulation piercing part of the clamp keeps the parts of the clamp at the same potential and prevents partial discharges and radio disturbances. The insulation piercing part also makes it possible to add an arc protection device to the clamp. SO255.2 comes with an adapter for hoist hook.

Product code	GTIN	For conductor mm ²	Conductor diameter mm	Tightening torque Nm	Weight (kg)	Pack. /pcs
SO255S	6438100324667	PAS / BLL 50-70 AlMgSi		40	1.13	9
SO255.2S	6438100324858	PAS / BLL-T 50-70 AlMgSi	12.7-16.7	40	1.25	9

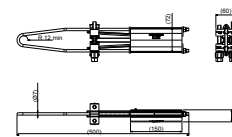

SO255S





Waterproof tension clamp SO256S and SO256.2S

For dead-ending covered conductors. The clamp is very easy to install compared with the other clamps on the market as there is no need to peel the conductor. The insulation piercing part of the clamp keeps the parts of the clamp at the same potential and prevents partial discharges and radio disturbances. The insulation piercing part also makes it possible to add an arc protection device to the clamp.

Product code	GTIN	For conductor mm ²	Conductor dia. mm	SMFL kN	Weight (kg)	Pack. /pcs
SO256S	6438100324872	PAS / BLL 95-157 AlMgSi	16.1-22.3	28.5	2.53	3
SO256.2S	6438100324865	PAS / BLL 95-157 AlMgSi	16.1-22.3	28.5	2.79	3

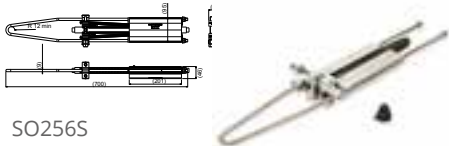

Tension clamp SO257S

Used with tension clamps SO255 or SO256 to create a temporary earthing point. A temporary earthing device with screw fixing can be installed to the horn.

Product code	GTIN	For conductor mm ²	Conductor diameter mm	Tightening torque Nm	Weight (kg)	Pack. /pcs
SO257S	6438100332129	MV CC 120-241	18.0-30.0	22-30	2.45	3



Earthing set PSS699

Used with tension clamps SO255 or SO256 to create a temporary earthing point. A temporary earthing device with screw fixing can be installed to the horn.

Product code	GTIN	Tightening torque	Weight (kg)	Pack. /pcs
PSS699	6438100320812	40	0.25	1

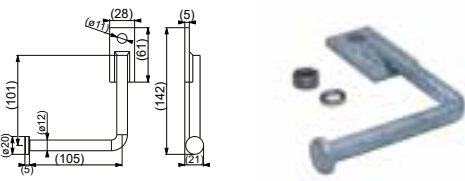

Helical tie sets CO and SO

Used with covered conductors for tying the conductors to the insulators. Can be used as both top and side ties. Easy to install without tools. The tie is installed on the insulation of the covered conductor. The sets include 6 pcs ties (one set/cross arm). The right size is easy to recognise by the colour code.

Product code	GTIN	Covered conductors mm ²	Colour code	Insulator neck mm	Weight (kg)	Pack. /pcs
CO35	6418677409165	35-50	Yellow	85	0.527	25
CO70	6418677409172	70-95	Green	85	0.65	25
CO120	6418677409134	120-150	Black	85	0.71	25
SO115.5073	6418677404085	35-62	Yellow	73	0.633	25
SO115.9573	6418677404108	70-99	Green	73	0.615	25
SO115.5085	6418677404092	35-62	Red	85	0.55	25
SO115.9585	6418677404115	70-99	Blue	85	0.617	25
SO115.150	6418677414329	120-157	White	73-85	0.665	25
SO216.62	6418677404566	62	White	73-85	0.63	25
SO216.99	6418677404573	99	Red	73-85	0.687	25
SO216.157	6418677404542	157	Blue	73-85	0.801	25
SO216.241	6418677404559	241	Yellow	85	1.6	25
SO216.24173	6438100312602	241	Yellow-green	73	0.92	10



CO35

Arc protection device SEW20.2 and SEW21.2

Used with covered conductors for arc protection. There is no need to peel the covered conductor. The connector includes an arc protection horn suitable also for use with temporary earthing devices with a screw fixing. The connector has a place for installing the Al-thread, which must be connected to the neck of the insulator. The products includes a 25 mm² Al thread 2.1 m.

Product code	GTIN	For conductor mm ²	Tightening torque Nm	Weight (kg)	Pack. /pcs
SEW20.2	6438100305543	BAS/BLL 50-157 AlMgSi	40	0.627	24
SEW21.2	6438100305512	PAS/BLL 150-241 AlMgSi	40	0,566	24

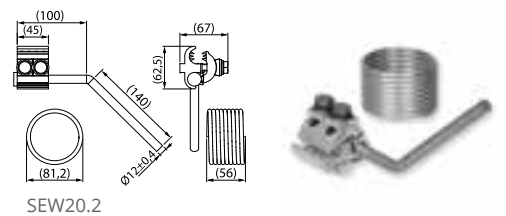

SEW20.2

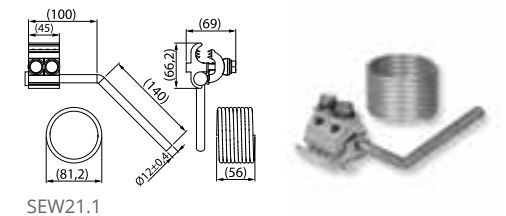

SEW21.2

Temporary earthing connector SEW20.3 and SEW21.3

Used as a temporary earthing connector where the arc protection devices SEW20.1 or SEW20.2 are not present. There is no need to peel the covered conductor. The connector includes an arc protection horn suitable for use with temporary earthing device with a screw fixing. The connector has a place for an Al-thread, so it also works as an arc protection device.

Product code	GTIN	For conductor mm ²	Tightening torque Nm	Weight (kg)	Pack. /pcs
SEW20.3	6438100305581	BLL/BLX 50-157 AlMgSi	40	0.56	24
SEW21.3	6438100306281	PAS/BLL-T 150-241 AlMgSi	40	0.56	24

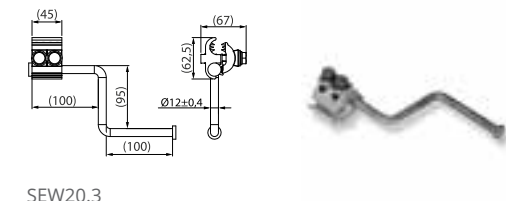

SEW20.3

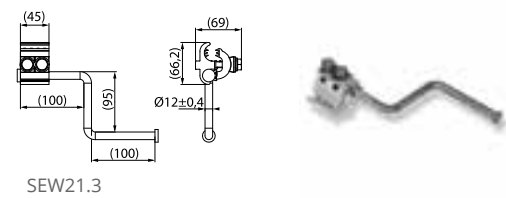

SEW21.3

Insulation piercing connector SEW30 and SEW31

The SEW30 and SEW31 are used for temporary earthing for Medium Voltage Covered Conductors (MV CC). The connector is watertight by silicone greased teeth. The nominal insulation thickness of the conductor can be between 2.3-4.0 mm.

Product code	GTIN	Main conductor mm ²	Tightening torque Nm	Weight (kg)	Pack. /pcs
SEW30	6438100320072	50-157 mm ² AlMgSi	35±2	1.09	6
SEW31	6438100320089	150-241 mm ² AlMgSi	35±2	1.09	6

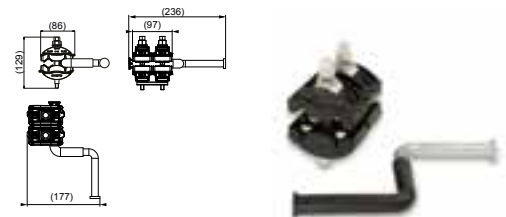

SEW30

Insulation piercing connector SLW26 and SLW27

The watertight shear head bolt connecto are for Medium Voltage Covered Conductors (MV CC) non-tension aluminium to aluminium connections without peeling the insulation. The nominal insulation thickness of the conductor can be between 2.3-4.0 mm.

Product code	GTIN	Main conductor mm ²	Tightening torque Nm	Weight (kg)	Pack. /pcs
SLW26	6438100309053	50-157 mm ² AlMgS	35±2	0.28	24
SLW27	6438100320065	150-241 mm ² AlMgSi	35±2	0.28	24

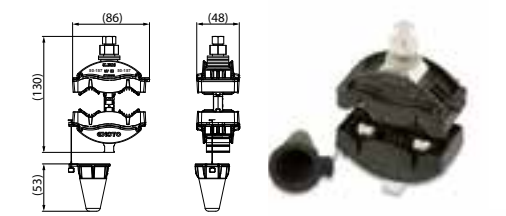

SLW26

Temporary earthing connector SEW20.31

Product code	GTIN	For conductor mm ²	Tightening torque Nm	Weight (kg)	Pack. /pcs
SEW20.31	6438100327309	BLL / BLX 50-157	40	0.56	24

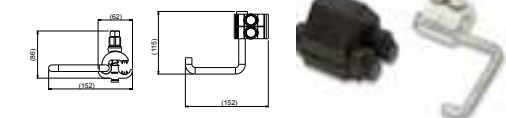

Insulation piercing connector SEW20.72

The connector SEW20.72 can be used for medium voltage covered conductor to bare conductor connections. The connector is watertight by silicone greased teeth and is equipped with shear head nuts.

Product code	GTIN	Weight (kg)	Pack. /pcs
SEW20.72	6438100322656	0.27	20

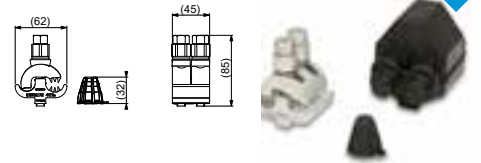

Insulation piercing connectors SLW25.22

Used as a branch connector for covered conductors. There is no need to peel the covered conductor because the connector is equipped with insulation piercing teeth. The connector is made of corrosion resistant aluminium and the bolts are hot-dip galvanized steel. The connector is prepared with joint compound. Can be used with insulation cover SP16.

Product code	GTIN	Main conductor mm ²	Branch conductor mm ²	Conductor diameter mm	Tightening torque Nm	Plastic cover	Weight (kg)	Pack. /pcs
SLW25.22	6438100304218	Al 50-157 AlMgSi	Al 50-157 AlMgSi	12.7-22.3	40	SP16	0.246	20

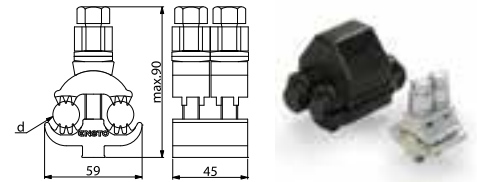

Live-line connector SLW36

The connector SLW36 is made of corrosion resistant aluminium and the bolts of stainless steel. The installation can be made with a live-line stick (e.g. CT48).

Product code	GTIN	Main conductor mm ²	Branch conductor mm ²	Tightening torque Nm	Weight (kg)	Pack. /pcs
SLW36	6438100304577	PAS/BLL-T 50-157 AlMgSi	PAS/BLL-T 50-157 AlMgSi	40	0.494	24

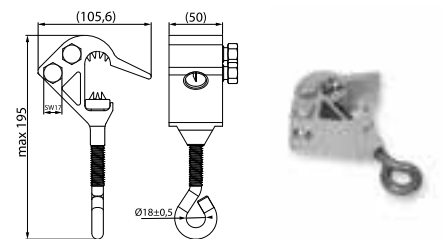

Stirrup PSS923

Branching and temporary earthing can be made with SL36 and SL30 by using stirrups PSS923 and PSS924. The stirrup is made of corrosion resistant aluminium. PSS923 is a stirrup of L-shape.

Product code	GTIN	Weight (kg)	Pack. /pcs
PSS923	6418677414299	0.109	100

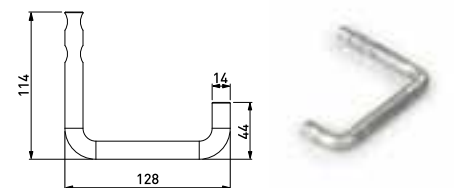

Stirrup PSS924

Branching and temporary earthing can be made with SL36 and SL30 by using stirrups PSS923 and PSS924. The stirrup is made of corrosion resistant aluminium. PSS924 is a stirrup of U-shape.

Product code	GTIN	Weight (kg)	Pack. /pcs
PSS924	6418677414305	0.181	50

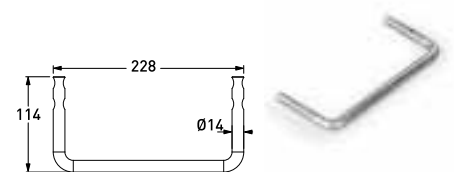

Live-line connectors SL30 and SL30.1

SL30 is used as a live-line branching connector for bare conductors. The connector is made of corrosion resistant aluminium and the bolts of stainless steel. The installation can be made with a live-line stick (e.g. CT48). Branching and temporary earthing can be made with SL30 and SL36 by using stirrups PSS923 and PSS924. The stirrups are made of corrosion resistant aluminium. PSS923 is a stirrup of L shape and PSS924 is a stirrup of U shape. In SL30 branching point is downwards. In SL30.1 the branching point is on the side of the connector.

Product code	GTIN	Main conductor mm ²	Branch conductor mm ²	Tightening torque Nm	Weight (kg)	Pack. /pcs
SL30	6418677403705	Al 25-150	Al 25-150	40/44	0.476	24
SL30.1	6418677411533	Al 25 - 150	Al 25-150	40/44	0.45	24

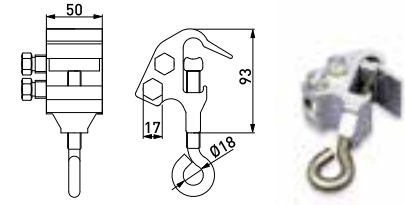

SL30

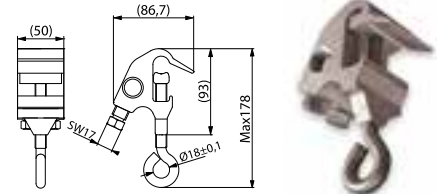

SL30.1

Sleeve PSS830

PSS830 is used with live-line connectors SL30, SL30.1 and SL36, when branch conductor is copper. The sleeve is tin coated aluminium and it is installed into live-line clamp. The inner diameter of the sleeve is 16 mm (outer 18 mm).

Product code	GTIN	Conductor size mm ²	Weight (kg)	Pack. /pcs
PSS830	6418677406737	25-95	0.008	300



Arc protection horn PSS464-P

Used with covered conductors as an arc protection horn. The horn withstands 2-3 arcs 10 kA/1 s and after that, it has to be changed. The horn has been approved for fixing temporary earthing device with screw fixing.

Product code	GTIN	Weight (kg)	Pack. /pcs
PSS464-P	6418677452130	0.2	25

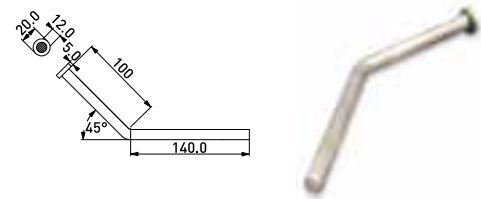

Earthing horn PSS469-P

Used with covered conductors as a temporary earthing point. The temporary earthing device with screw fixing can be installed to the horn.

Product code	GTIN	Weight (kg)	Pack. /pcs
PSS469-P	6418677452147	0.3	25

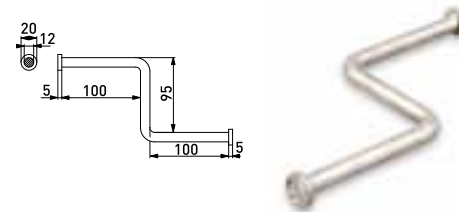

Earthing horn PSS597

Used on pole transformers when temporary earthing is made on jumpers. The horn has been approved for screw type temporary earthing devices. The horn is installed on conductor with SL4.25 or SEW20.72 connectors and insulating covers. The earthing horns can be installed on different heights in the conductors.

Product code	GTIN	Weight (kg)	Pack. /pcs
PSS597	6418677406584	0.2	25

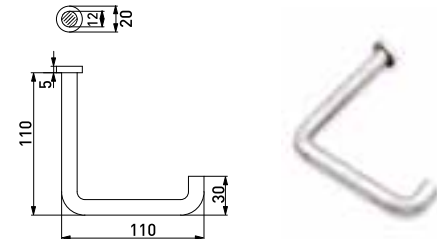



Current limiting arc horn SDI46 series

The sets includes a surge arrester, a fixing bracket, an insulation piercing connector, an arc protection horn and a connector cover:

SDI46.7 and SDI46.710 are suitable for pin insulators.

SDI46.5 and SDI46.510 are suitable for line-post insulators.

SDI46.545-10 is used on straight line crossarms with post line insulators for arc protection.

Product code	GTIN	Highest system voltage kV	Insulator attachment type	Weight (kg)	Pack. /pcs
SDI46.7	6418677401626	24	Pin	3.0	1
SDI46.710	6418677419102	12	Pin	2.3	1
SDI46.5	6418677418631	24	Line-post	3.86	1
SDI46.510	6418677418655	12	Line-post	3.16	1

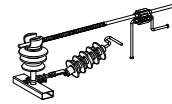
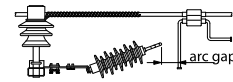

SDI46.7

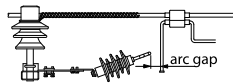

SDI46.710

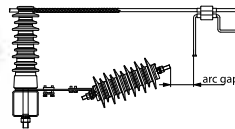

SDI46.710

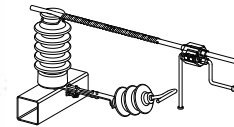

SDI46.510



Current limiting device SDI3143.2

The use of current limiting devices on transformer covers is as beneficial as when used in the protection of covered conductors. The number of high-speed automatic reclosures can be reduced significantly compared to the widely used power arc devices – thus, a resistant and maintenance-free protection method is achieved. Ensto has renewed the product range of its current limiting devices for small transformers (< 200 kVA). A special attention has been given to easy usability:

- All necessary parts with one product code
- Easy to adjust surge arrester support
- Use of the familiar KG connector in connecting the bushing insulator of the transformer
- Easy to install protective covers

The set includes:

- 3 surge arresters
- 3 electrodes attached to the bushing insulator of the transformer
- 3 protective covers with fasteners
- A surge arrester support with fasteners



Product code	GTIN	Weight (kg)	Pack. /pcs
SDI3143.2	6418677453618	12.5	1
SDI48.5	6438100324926	5.18	3
SDI48.510	6438100324933	4.61	3
SDI48.6	6438100324940	5.18	3
SDI48.610	6438100324957	4.61	3



Surge arrester set SDI2024.10

Protection of pole mount transformers against atmospheric and switching over-voltages. Surge arrester have been designed and tested according to IEC 60099-4/2004.

A special attention has been given to easy usability:

- All necessary parts with one product code
- Surge arrester rack is easy to adjust
- Use of the familiar KG connector in connecting the transformer bushing insulator to surge arrester
- Protective covers are easy to install

The set includes:

- 3 surge arresters
- A surge arrester rack with fasteners
- 6 protective covers with fasteners
- 6 busbar connectors for connecting the transformer bushing insulators to surge arresters
- A busbar connector for grounding the surge arrester rack

Product code	GTIN	Weight (kg)	Pack. /pcs
SDI2024.10	6438100300586	23.95	1



Surge arrester set SDI2327.10

Protection of pole mount transformers against atmospheric and switching over-voltages. Surge arrester have been designed and tested according to IEC 60099-4/2004.

A special attention has been given to easy usability:

- All necessary parts with one product code
- Surge arrester rack is easy to adjust
- Use of the familiar KG connector in connecting the transformer bushing insulator to surge arrester
- Protective covers are easy to install

The set includes:

- 3 surge arresters
- A surge arrester rack with fasteners
- 6 protective covers with fasteners
- 6 busbar connectors for connecting the transformer bushing insulators to surge arresters
- A busbar connector for grounding the surge arrester rack

Product code	GTIN	Weight (kg)	Pack. /pcs
SDI2327.10	6438100300593	24.55	1





Automatic tension joints CIL

The automatic joint is easy and quick to make. No special tools are needed for the installation. Assembly without flame is faster and easier. The wedge type automatic joint ensures a safe cable joint. Includes two cold shrink insulation sleeves together with mastics and tapes for making the joint.

Product code	GTIN	Cable outer sheath diameter mm	Conductor diameter mm	For conductor size mm²	Weight (kg)
CIL106	6438100320621	11-15	5.8-8.6	MV CC 35-50	0.26
CIL107	6438100320225	14-18	9.2-12	MV CC 50-70	0.47
CIL108	6438100320607	17.5-22	12.8-14.9	MV CC 99-120	0.79
CIL109	6438100320614	20-25	14.7-18.4	MV CC 157	0.85
CIL110	6438100327330	25-30		MV CC 241	1.95

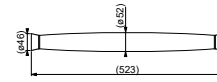

CIL109



Spiral vibration dampers CO27 and CO28

Spiral Vibration Dampers are designed to control high frequency aeolian vibration and are particularly effective on small sized earth wires and cables. They do not impose a concentrated mass or clamping stress on the conductor or cable at the point of attachment and are therefore ideally suited for use on PAS/BLL, OPGW, OPCON and ADSS applications.

Product code	GTIN	Covered conductors mm²	Weight (kg)	Pack. /pcs
CO27	6418677409141	35-50	0.46	1
CO28	6418677409158	70-157	1.0	1



CO28

Bird Protectors

Bird protector set SP45.3

SP45.3 bird protectors prevent failures created by birds or other animals in bare or covered lines. These protectors are suitable for different pin and line post insulators. They are also easy to install even in line angles or when the conductor is attached to the neck of the insulator. SP45.3 covers arc protecting devices (i.e. SE20.2) in covered conductor lines and it is weather resistant. The SP45.3 bird protector is 1000 mm long. Extra length can be achieved in combination with SP31.3. One set consists of 3 units.

Product code	GTIN	Weight (kg)	Pack. /pcs
SP45.3	6418677405327	0.875	

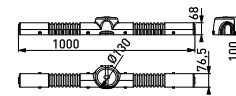

Bird protector set SP60.3

SP60.3 bird protectors prevent failures created by birds or other animals in bare or covered lines. This protector is suitable for different pin and line post insulators. It is also easy to install even in line angles or when the conductor is attached to the neck of the insulator. SP60.3 covers arc protecting devices (i.e. SE20.2) in covered conductor lines and it is weather resistant. SP60.3 can be installed in a live line with the aid of special tools. Delivered in complete sets of 3 pcs.

Product code	GTIN	Weight (kg)	Pack. /pcs
SP60.3	6418677441714	1.83	1

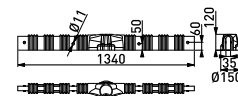

Bird protector set SP62.3

SP62.3 is a bird protection set for pulley suspension clamp SO181.6. The products are manufactured of weather and UV-resistance thermo plastic. The bird protectors prevent failures created by birds or other animals or flying branches in bare or covered lines. The bird protectors are easy to install due to snap-on fixings.

Product code	GTIN	Weight (kg)	Pack. /pcs
SP62.3	6438100301163	0.390	1

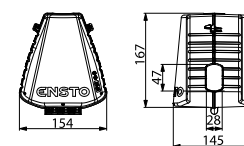

Bird protector set SP63.3

SP63.3 is a bird protection set for dead-end clamp SO255. The products are manufactured of weather and UV-resistance thermo plastic. The bird protectors prevent failures created by birds or other animals.



Product code	GTIN	Weight (kg)	Pack. /pcs
SP63.3	6438100305826	0.891	1

Bird protector set SP67.3

SP67.3 is a bird protection set for tension clamp SO256. The products are manufactured of weather and UV-resistance thermo plastic. The bird protectors prevent failures created by birds or other animals. Set includes covers for three phases.

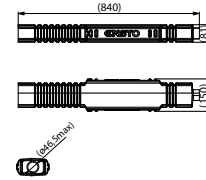

Product code	GTIN	Weight (kg)	Pack. /pcs
SP46.3	6418677405334	0.226	8

Bird protector set SP46.3 for underground cable terminals

Prevents short-circuiting by large birds or airborne debris at surge arresters or cable terminals in medium voltage networks. Bare jumpers can be protected with flexible protectors SP31.3. Made of weather and UV resistant plastic. One set consists of 3 units.

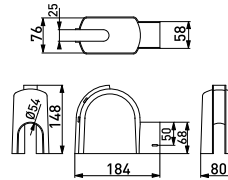

Product code	GTIN	Weight (kg)	Pack. /pcs
SP46.3	6418677405334	0.226	8

Cable protector set SP31.3

Flexible cover for jumpers or conductors close to insulators. Can be used together with SP36.3 for pin insulators or transformer bushings. Easy tie fixing. Made of weather and UV resistant plastic. One set consists of 3 units.

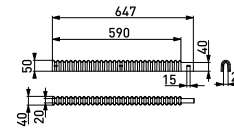

Product code	GTIN	Weight (kg)	Pack. /pcs
SP31.3	6418677405266	0.3	1

Bird protection set SP36.3

Used for bushings, insulators and surge arresters in dia. 100-180 mm. Can be used together with flexible protector SP31.3. Easy tie fixing. Made of weather and UV resistant plastic. One set consists of 3 units.

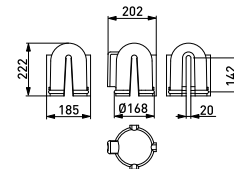

Product code	GTIN	Weight (kg)	Pack. /pcs
SP36.3	6418677405280	0.445	6

Bird protection set SP38.3

Flexible cover for low voltage bushings, transformers and motors. Easy tie fixing. Made of weather and UV resistant rubber. One set consists of 3 units.

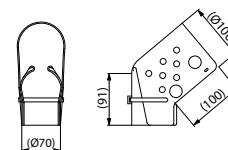

Product code	GTIN	Weight (kg)	Pack. /pcs
SP38.3	6418677405297	0.4	10



Insulating cover SP15

SP15 is used as a connector cover. The cover has to be installed so that the drain hole for ambient water is downwards. The cover is made of UV-radiation and weather resistant thermoplastic. Suitable for SM2.1, SM2.11, SM2.2, SM2.21, SM2.25, SL4.2, SL4.21, SL4.25, SL4.26, SL37.1, SL37.2 and SL39.2

Product code	GTIN	Weight (kg)	Pack. /pcs
SP15	6418677405211	0.031	100

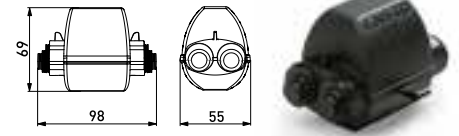

Insulating cover SP16

SP16 is used as a connector cover. The cover has to be installed so that the drain hole for ambient water is downwards. The cover is made of UV-radiation and weather resistant thermoplastic. Suitable for SM4.2, SM4.21, SL8.2, SL8.21, SL14.2, SL25.2, series SE20 and SE21.

Product code	GTIN	Weight (kg)	Pack. /pcs
SP16	6418677410208	0.037	50

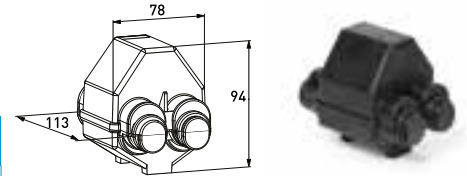

Number plates PEM241

Used with conductors to mark the phases. Made of UV radiation resistant plastic. The plates are installed by nylon ties.

Product code	GTIN	Plate no.	Weight (kg)	Pack. /pcs
PEM241.1	6418677400445	1	0.007	100
PEM241.2	6418677400476	2	0.007	100
PEM241.3	6418677400490	3	0.007	100

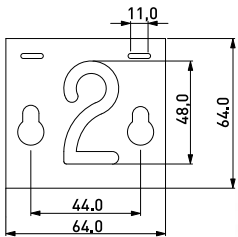

PEM241.1

PEM241.2

PEM241.3

SZ24 Disconnecter is an ideal solution for MV overhead lines

Disconnecter

Disconnecter SZ24

SZ24 is easy and quick to install even on existing lines as no additional construction is needed. SZ24 disconnecters is 1-pole operated by standard live-line tools e.g. Ensto's CT48.64. SZ24 is tested and approved according to the newest international standards. Its breaking capacity is 12.5 A, sufficient for rural areas on branch lines.

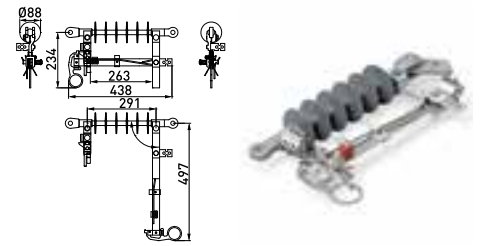

Rated values	
Voltage Ur	24 kV
*Power frequency withstand voltage, 1 min, 50 Hz	50 kV, 60 kV
*Lightning withstand voltage	125 kV, 145 kV
Frequency	50 Hz
Normal current Ir	400 A
Short time withstand current Ik	10 kA
Peak withstand current Ip	25 kA
Duration of short circuit tk	1 s
Mechanical endurance class M0	1000 operating cycles
Mainly active load-breaking current I1	12.5 A (30 co)
Cable charging breaking current 14a	10 A (30 closing and opening operations)
Line-charging breaking current 14b	10 A (30 closing and opening operations)
Leakage distance, minimum	628 mm
Ice breaking capacity	10 mm



Pole-mounted transformer substation

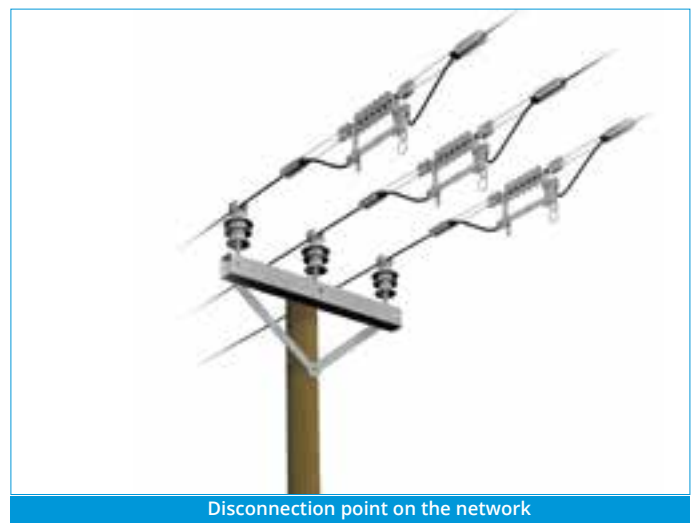

Disconnection point on the network



With cable termination

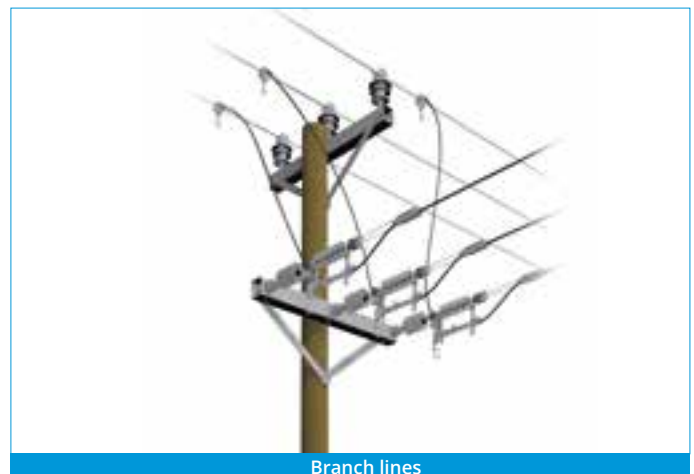

Branch lines

Covered Conductor Solution

Composite tension insulator SDI95.1

SDI95.1 composite tension insulator is used for bare or covered MV overhead lines. Insulators body is made from composite (silicone + glass fibre) and the end fittings are hot dip galvanized steel.

Product code	GTIN	SMFL kN	Creepage distance mm	Dry lightning impulse withstand voltage kV	Wet power frequency withstand voltage kV	Weight (kg)	Pack. /pcs
SDI95.1	6438100316655	80	1120	210	110	1.4	3

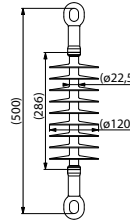

Composite line post Insulators SDI84.x

Ensto's new SDI84.x line post insulators are attached to the crossarm with bolts included in the package. Line post insulators fulfill the requirements of IEC 61952:2008, IEC 60060-1:2010. Coating is made of two-component silicone, that gives the insulator excellent dielectric strength and makes it resistant to UV radiation and harsh weather conditions. The upper fitting in order to reduce the concentration of electric field around the insulator upper fitting, it is made of insulating plastic material (PA6-GF30). Because Ensto's new composite line post insulators cause no partial discharges, the RF disturbances are eliminated.

Product code	GTIN	SMFL kN	Creepage distance mm	Dry lightning impulse withstand voltage kV	Wet power frequency withstand voltage kV	Weight (kg)	Pack. /pcs
With M20 bolt							
SDI84.1M20	6438100316037	12.5	1168	181	92	2.96	1
SDI84.1M24	6438100316044	12.5	1168	181	92	2.96	1

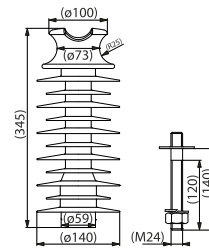

SDI84.1M24



Power arc device SDI27.1

Power arc device SDI27.1 is used with SDI90.x composite insulators on angle poles with suspension clamp SO181.5 and on tension poles with tension clamps SO235 or SO236. The package includes arching horns and 95 mm² conductor with cable lugs. Spark gap is adjustable.

Product code	GTIN	Weight (kg)	Pack. /pcs
SDI27.1	6418677419133	0.83	9

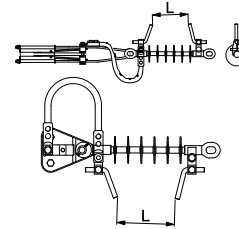

Power arc device SDI20.2

Power arc device SDI20.2 is used as a arcing protection device for covered conductors. The device is suitable for horizontal suspension crossarms that are equipped with line post insulators e.g. SDI81. Nominal thickness of covering may vary from 2.0 mm up to 3.6 mm. Spark gap is adjustable.

Product code	GTIN	Weight (kg)	Pack. /pcs
SDI20.2	6418677418600	1.25	12

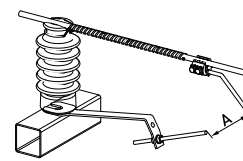

Suspension clamp SO181.6S

Suspension clamp with pulley for covered conductors PAS/BLL AlMgSi and for insulated messengers of aerial MV cables like AHXAMK-WM3 (Multi-wiski). The clamp also functions as an installation pulley thereby completely eliminating the need for separate pulleys. Conductor joints with diameter under 30 mm can be pulled through the suspension clamp. The suspension clamp has no loose parts, so it is easy to handle even in difficult conditions. The insulation piercing contact part has a silicone seal which prevents the moisture getting into the conductor. The insulation piercing clamp piece is connected to the body with a wire for balancing the potential. The product is tested for radio interference. SMFL 30 kN. Suspension bolt 16 mm.

Product code	GTIN	For conductor mm ²	Conductor diameter mm	Tightening torque Nm	Weight (kg)	Pack. /pcs
SO181.6S	6438100324841	PAS/BLL 50-157 AlMgSi	12.7-22.3	40	1.224	3

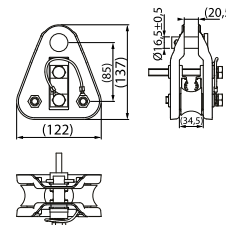

Waterproof tension clamp SO255

Tension clamp for covered conductors (PAS/BLL AlMgSi and for insulated messengers of aerial MV cables like AHXAMK-WM3 (Multi-wiski). The insulation piercing contact part has silicone seal which prevents the moisture getting into the conductor.

Product code	GTIN	For conductor mm ²	Conductor dia. mm	SMFL kN	Weight (kg)	Pack./ pcs
SO255	6438100303846	PAS/BLL 50-70 AlMgSi	12.7-16.7	18	1.133	9
SO255S	6438100324667	PAS/BLL 50-70 AlMgSi		20	1.13	9

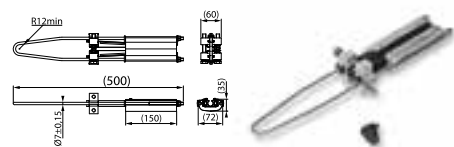

Waterproof tension clamp SO256

Tension clamp for covered conductors PAS/BLL AlMgSi and for insulated messengers of aerial MV cables like AHXAMK-WM3 (Multi-wiski). The insulation piercing contact part has silicone seal which prevents the moisture getting into the conductor.

Product code	GTIN	For conductor mm ²	Conductor dia. mm	SMFL kN	Weight (kg)	Pack./ pcs
SO256	6438100303822	PAS/BLL 95-157 AlMgSi	16.1-22.3	30	2.53	3
SO256S	6438100324872	PAS/BLL 95-157 AlMgSi	16.1-22.3	28.5	2.53	3

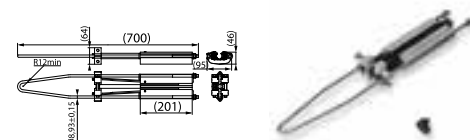

Bird protector set SP62.3

SP62.3 is a bird protection set for pulley suspension clamp SO181.6. The products are manufactured of weather and UV-resistance thermo plastic. The bird protectors prevent failures created by birds or other animals or flying branches in bare or covered lines. The bird protectors are easy to install due to snap-on fixings.

Product code	GTIN	Weight (kg)	Pack./ pcs
SP62.3	6438100301163	0.390	1

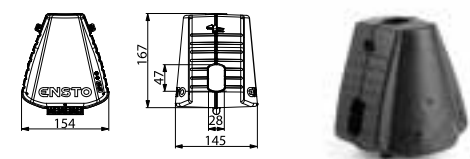

Bird protector set SP63.3

SP63.3 is a bird protection set for dead-end clamp SO255. The products are manufactured of weather and UV-resistance thermoplastic. The bird protectors prevent failures created by birds or other animals.

Product code	GTIN	Weight (kg)	Pack./ pcs
SP63.3	6438100305826	0.891	1
SP67.3	6438100322946		1



Helical tie SO115 series

Used with covered conductors for tying the conductors to the insulators. Can be used as both top and side ties. Easy to install without tools. The tie is installed on the insulation of the covered conductor. The sets include 6 pcs ties (one set/cross arm). The right size is easy to recognise by the colour code.

Product code	GTIN	Covered conductors mm ²	Colour code	Insulator neck mm	Weight (kg)	Pack./ pcs
SO115.5073	6418677404085	35-62	Yellow	73	0.633	25
SO115.9573	6418677404108	70-99	Green	73	0.615	25
SO115.5085	6418677404092	35-62	Red	85	0.55	25
SO115.9585	6418677404115	70-99	Blue	85	0.617	25
SO115.150	6418677414329	120-157	White	73-85	0.665	25

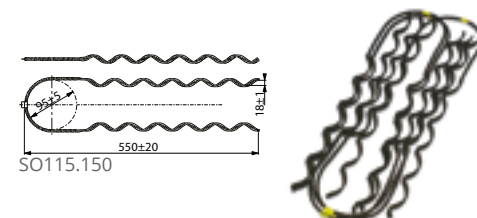

Crossarms

Ensto crossarms are designed to meet the requirements of the network with respect to tension forces, angles and conductor clearances. The crossarms are made of corrosion resistant, hot-dip galvanized steel.

Product code	GTIN	Weight (kg)	Pack. /pcs
SH153.10	6418677406843	29.6	1
SH1524.1	6438100327590	35	1
SH180	6438100329396	40.4	1
SH179	6438100329389	31.5	1
SH156	6418677406874	19	1
SH253	6418677422942	25.1	1

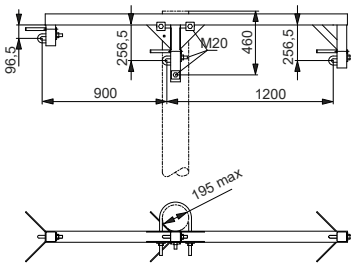

SH153.10

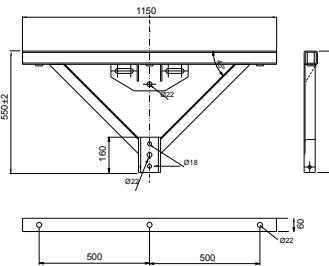

SH1524.1

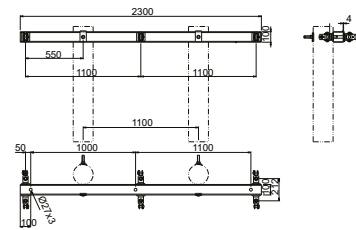

SH180

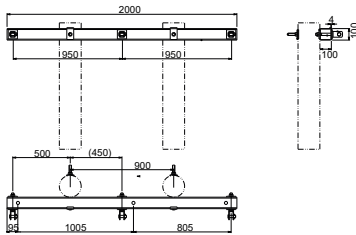

SH179

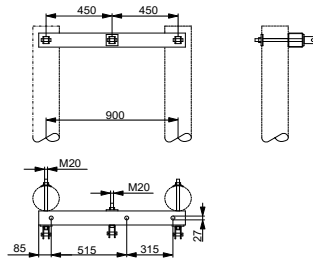

SH156

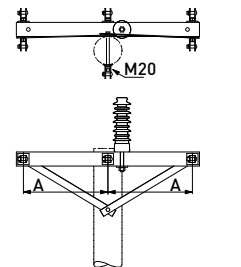

SH253

Medium Voltage Bare Conductor Solution

Pin insulator SDI37

SDI37 is used with bare wires or covered conductors. Suitable for installation on pin SOT24 (SFS 4385). The plastic sleeve in the top-groove of the insulator enables pulling of conductor without using pulleys. The conductor can be tied to the top-groove or to the neck. In angles, always tie to the neck. Creepage distance 325 mm. Neck diameter 85 mm.

Product code	GTIN	Highest system voltage kV	Breaking load kN	Insulator pin	Weight (kg)	Pack. /pcs
SDI37	6418677408731	24	12.5	SOT24	3.8	3

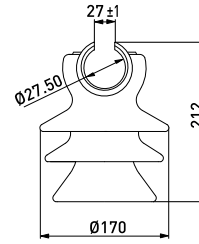

Pin insulator SDI30

SDI30 is used with bare wires or covered conductors. Suitable for installation on pin SOT24 (SFS 4385). The conductor can be tied to the top-groove or to the neck. In angles, always tie to the neck. Creepage distance 325 mm. Neck diameter 85 mm.

Product code	GTIN	Highest system voltage kV	Breaking load kN	Insulator pin	Weight (kg)	Pack. /pcs
SDI30	6418677408748	24	12.5	SOT24	3.37	3

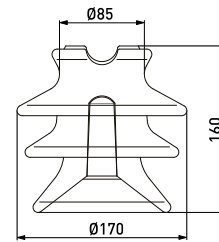

Composite insulators SDI90 series

Composite tension insulator SDI90 series are used for terminal and intermediate poles of 36 kV lines. Creepage distance 613 mm.

Product code	GTIN	End fittings	Highest system voltage kV	Weight (kg)	Pack. /pcs
SDI90.150	6418677422669	eye / eye	24	0.995	3
SDI90.280	6418677422768	eye / eye	36	1.08	3
SDI90.282	6418677422782	socket / eye	36	1.3	3
SDI90.283	6418677422799	ball / socket	36	1.1	3
SDI90.284	6418677422805	clevis / tongue	36	1.3	3
SDI90.285	6418677422812	clevis / ball	36	1.2	3
SDI90.288	6418677422843	socket / tongue	36	1.3	3



SDI90.283

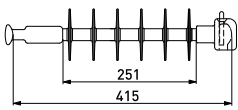

SDI90.150

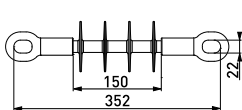

SDI90.280

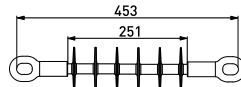

SDI90.284

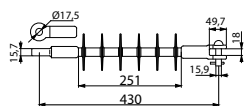

SDI90.282

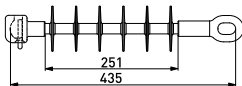

SDI90.288

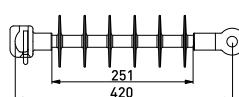

Composite line post insulators SDI82 and SDI84

Ensto's new SDI82 and SDI84 line post insulators are attached to the crossarm with bolts included in the package. Line post insulators fulfill the requirements of IEC 61952:2008, IEC 60060-1:2010. Coating is made of two-component silicone, that gives the insulator excellent dielectric strength and makes it resistant to UV radiation and harsh weather conditions. The upper fitting in order to reduce the concentration of electric field around the insulator upper fitting, it is made of insulating plastic material (PA6-GF30). Because Ensto's new composite line post insulators cause no partial discharges, the RF disturbances are eliminated.

Product code	GTIN	SMFL kN	Creepage distance mm	Dry lightning impulse withstand voltage kV	Wet power frequency withstand voltage kV	Weight (kg)	Pack./ pcs
With M20 bolt							
SDI82.1M20	6438100316013	12.5	561	156	72	2.56	1
SDI83.1M20	6438100316020	12.5	688	156	77	2.63	1
SDI84.1M20	6438100316037	12.5	1168	181	92	2.96	1
With M24 bolt							
SDI84.1M24	6438100316044	12.5	1168	181	92	2.96	1

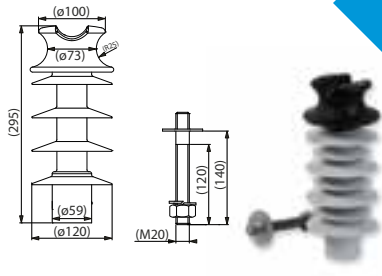

SDI82.1M20

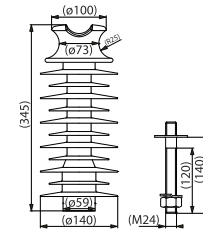

SDI84.1M24

Glass tension insulator strings SH193

Suitable for installation on angle and terminal crossarms as well as hooks. The insulators are 24 - 52 kV glass insulators U40BL according to IEC 60305. They are tested according to IEC 60383:1983. Breaking load is 40 kN.

Product code	GTIN	End fittings	Highest system voltage kV	Weight (kg)	Pack. /pcs
SH193	6418677407062	ball-socket	24	4.40	1
SH193.453	6418677441424	ball-socket	36	6.16	1
SH193.454	6418677414114	ball-socket	52	7.92	1
SH193.455	6418677414121	ball-socket	52	9.68	1

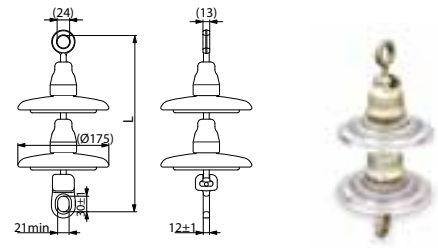

SH193

Stay insulator SDI4.5

Porcelain stay insulator is suitable for installation in stay wires up to 52 mm². Conforms with standard SFS 3741. Creepage distance is 95 mm.

Product code	GTIN	Highest system voltage kV	Max continuous load kN	SMFL kN	Weight (kg)	Pack. /pcs
SDI4.5	6418677418556	24	35	120	2.15	6

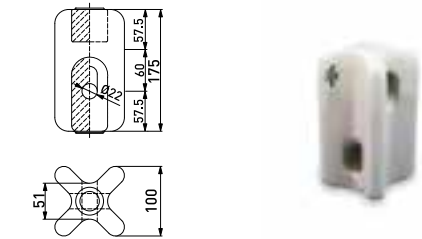

Composite stay insulators SDI70.24 and SDI70.72

SDI70.24 insulator has high mechanical and electrical capacity combined with light weight. The insulating section is made of glass fibre impregnated with UV stabilized resin and twice covered silicon rubber. The end thimble is made of aluminium and dimensioned for minimum 52 mm eyelet. SDI70.24 is suitable for installation on stay wires up to Fe52 and is tested according to IEC 60383. Ordinary mechanical load 48 kN, max. mechanical load 144 kN, specified mechanical load 180 kN. Creepage distance 160 mm.

Product code	GTIN	Highest system voltage kV	Max continuous load kN	SMFL kN	Weight (kg)	Pack. /pcs
SDI70.24	6418677401787	24	35	180	0.8	15
SDI70.72	6418677401794	72	35	130	1.27	20

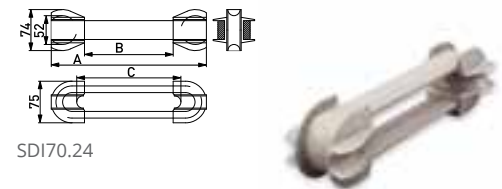

SDI70.24

Suspension clamp SO181

Suitable for bare conductors. The clamp also functions as an installation pulley thereby completely eliminating the need for separate pulleys. Conductor joints with diameter under 30 mm can be pulled through the suspension clamp. Has no loose parts, so it is easy to handle even in difficult conditions. The serrated clamping piece is connected to the body with a wire for balancing the potential. Tested for radio interference. Breaking strength >36 kN. Suspension bolt 16 mm.

Product code	GTIN	For conductor mm ²	Conductor diameter mm	Tightening torque Nm	Weight (kg)	Pack. /pcs
SO181	6418677404474	Al/Fe 25-131, AAAC 35-241	6.3-20.2	20	1.192	3

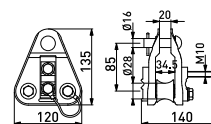

Suspension clamps SO241

The suspension clamp SO241 is suitable for bare conductors at medium and low voltages. The body is made of corrosion resistant aluminium alloy and the bolt is of hot-dip galvanized steel. SO241 suspension bolt diameter is 16 mm and breaking load is >50 kN. SO241.2 suspension bolt diameter is 19 mm and breaking load is >50 kN.

Product code	GTIN	For conductor mm ²	Conductor diameter mm	Tightening torque Nm	Weight (kg)	Pack. /pcs
SO241	6418677416309	AAAC 25-201, ACSR 25-110	6-18.5	40	0.55	25
SO241.2	6418677416316	AAAC 25-201, ACSR 25-110	6.0-18.5	40	0.617	25

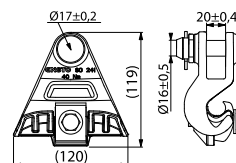

SO241



Tension clamp SO85

For dead-ending bare and covered conductors. The body is made of corrosion resistant aluminium alloy and the bolts are hot dip galvanized steel. Breaking load is 35 kN. SO85 suspension bolt diameter is 16 mm. SO85.2 suspension bolt diameter is 19 mm.

Product code	GTIN	For conductor mm ²	Conductor diameter mm	Tightening torque Nm	Weight (kg)	Pack. /pcs
SO85	6418677405112	AAAC 25 - 150, PAS 35-150, ACSR 25 - 99	6-14.9	55	0.743	25
SO85.2	6418677405136	AAAC 25 - 132, PAS 35-120,, ACSR 25 - 99	6-14.9	55	0.781	25

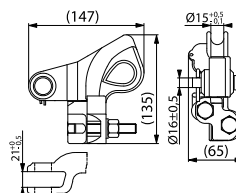

SO85



Tension clamp SO105

For dead-ending bare and covered conductors. The body is made of corrosion resistant aluminium alloy and the bolts are hot dip galvanized steel. Breaking load >50 kN. Suspension bolt diameter is 16 mm.

Product code	GTIN	For conductor mm ²	Conductor diameter mm	Tightening torque Nm	Weight (kg)	Pack. /pcs
SO105	6418677404030	AAAC 95 - 241, ACSR 63 - 98, ACSR 131, PAS/BLL 95 - 157	10-20	44	1.208	10

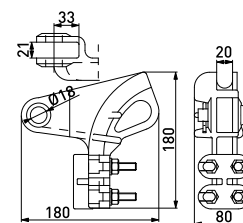

Tension clamp SO146

Used for dead-ending bare and covered conductors. The body is made of corrosion resistant aluminium alloy and the bolts are hot-dip galvanized steel. The conductor is inserted on one side and clamped by two bolts. Breaking load >35 kN. Suspension bolt diameter is 16 mm

Product code	GTIN	For conductor mm ²	Conductor diameter mm	Tightening torque Nm	Weight (kg)	Pack. /pcs
SO146	6418677404436	AAAC 25 - 150, Al/Fe 25 - 99, PAS/BLL 35 - 150	6-15	55	0.9	10

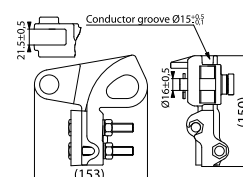

Tension clamp SO255.1

Tension clamp for bare conductors as Swan, Sparrow, Raven, Pigeon and AAC132.

Product code	GTIN	For conductor mm ²	Conductor dia. mm	SMFL kN	Weight (kg)	Pack. /pcs
SO255.1	6438100303853	Swan, Sparrow, Raven, Pigeon and AAC132.	6.36-14.9	20	1.192	9

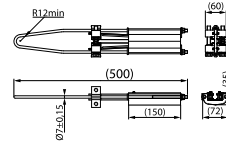

Live-line connector SL30

Used with bare conductors as a live-line branching connector. The connector is made of corrosion resistant aluminium and the bolts of stainless steel. For copper branch conductors sleeve PSS830 is needed. The installation can be made with a live-line stick (e.g. CT48). In SL30 branching point is downwards. In SL30.1 the branching point is on the side of the connector.

Product code	GTIN	Main conductor mm ²	Branch conductor mm ²	Tightening torque Nm	Weight (kg)	Pack. /pcs
SL30	6418677403705	Al 25-150	Al 25-150	40/44	0.476	24
SL30.1	6418677411533	Al 25-150	Al 25-150	40/44	0.45	24

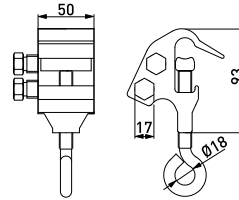

SL30

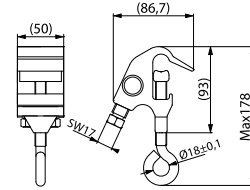

SL30.1

Sleeve PSS830

PSS830 is used with live-line connectors SL30, and SL30.1 when the branch conductor is copper. The sleeve is tin coated aluminium and it is installed into the live-line clamp. The inner diameter of the sleeve is 16 mm (outer 18 mm).

Product code	GTIN	Conductor size mm ²	Weight (kg)	Pack. /pcs
PSS830	6418677406737	25-95	0.008	300

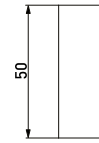

SL4.25

SL8.21

Parallel groove connectors SL4.25 and SL8.21

For aluminium or steel to aluminium connections where no mechanical tension is involved. The lower section of the body protects the bolts from corrosion and makes tightening of the bolts easy, using fork wrench ST34. The correct tightening torque is essential to the connection. The body is made of corrosion resistant aluminium alloy, and the bolts are hot-dip galvanized steel. All connectors are pre-brushed and prepared with joint compound. SL4.25 is equipped with springs to make the installation even easier.

Product code	GTIN	Main conductor mm ²	Branch conductor mm ²	Conductor diameter mm	Tightening torque Nm	Plastic cover	Weight (kg)	Pack. /pcs
SL4.25	6418677403750	Al 16-120	Al 16-120	4.6-13.5	20	SP15	0.128	50
SL8.21	6418677403781	Al 50-240	Al 50-240	7.7-20	44	SP16	0.29	25

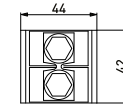
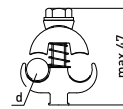

SL4.25

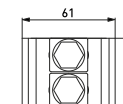
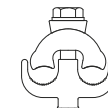

SL8.21



Parallel groove connector SL14.2

SL14.2 is for Al or Cu connections where no mechanical tension is involved. The body is made of tin plated aluminium alloy, and the bolts are hot-dip galvanized steel.

Product code	GTIN	Main conductor mm ²	Branch conductor mm ²	Conductor diameter mm	Tightening torque Nm	Plastic cover	Weight (kg)	Pack. /pcs
SL14.2	6418677403552	Al/Cu 50-240	Al 50-185 / Cu 50-150	7.7-20	44	SP16	0.28	25

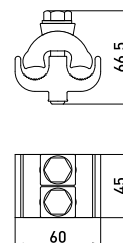

Parallel groove connectors SL37.1 and SL37.2

SL37.1 and SL37.2 are used for aluminium or steel to aluminium connections where no mechanical tension is involved. The correct tightening torque is essential to the connection. SL37.271 is suitable for copper and aluminium connections. SL37.271 is equipped with shear head bolts.

Product code	GTIN	Main conductor mm ²	Branch conductor mm ²	Conductor diameter mm	Tightening torque Nm	Plastic cover	Weight (kg)	Pack. /pcs
SL37.1	6418677414404	Al 6-95	Al 6-95	3-13 / 3-13	22	SP15	0.055	200
SL37.2	6418677414411	Al 6-95	Al 6-95	3-13 / 3.5-13	22	SP15	0.1	50
SL37.271	6418677450273	Al/Cu 6-95	Al 6-95 / Cu 6-70	3-13	22	SP15	0.11	50



Parallel groove connector SL39.2, SL39.27 and SL39.271

SL39.2 is used for aluminium or steel to aluminium and SL39.27 is suitable for copper and aluminium connections. The correct tightening torque is essential to the connection. SL39.271 is equipped with shear head bolts. The connectors are used when no mechanical tension is involved.

Product code	GTIN	Main conductor mm ²	Branch conductor mm ²	Conductor diameter mm	Tightening torque Nm	Plastic cover	Weight (kg)	Pack. /pcs
SL39.2	6418677419607	Al 16-150	Al 16-150	4.5-17.5	22	SP15	0.12	50
SL39.27	6418677438905	Al/Cu 16-150	Al 16-150 / Cu 10-120	4.5-17.5	22	SP15	0.12	50
SL39.271	6418677450280	Al/Cu 16-150	Al 16-150 / Cu 10-120	4.5-17.5	22	SP15	0.13	50

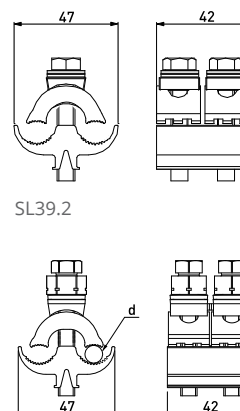

Automatic tension joints CIL

The automatic joints are reliable and fast to make. The installation can be made without tools. The colour codes make it easy to identify the right type. The wedges ensure a safe joint.

Product code	GTIN	For conductor mm ²	Conductor dia. mm	Colour code	Weight (kg)	Pack. /pcs
CIL63	6418677414220	35 - 50	5.81-8.64	orange / red	0.155	25
CIL64	6418677414237	70 - 95	9.27-12.06	yellow / grey	0.278	25
CIL65	6418677414244	120 - 150	12.75-14.86	pink / black	0.478	25
CIL71	6418677417726	-	14.73-18.4	green / brown	0.840	10
CIL72	6418677418440	-	18.8-21.7	blue / green	1.08	10



Automatic joints CIL9

CIL9 automatic tension joints are used for universal cables with steel messenger and also for stay wire applications.

Product code	GTIN	For conductor mm ²	Conductor dia. mm	Weight (kg)	Pack. /pcs
CIL9.25	6418677418549	Fe 25	5.46-6.86	0.2721	25
CIL9.68	6418677418532	Fe 68	9.96-11.56	0.726	25



Dead ends COL25, COL33 and COL52

Automatic stay wire clamps are used for steel stay wire or steel messenger wire.

Product code	GTIN	For conductor mm ²	Conductor dia. mm	Weight (kg)	Pack. /pcs
COL25	6418677418495	Fe 25	5.46-6.86	0.236	50
COL33	6418677418501	Fe 33	6.86-8.00	0.380	25
COL52	6418677418518	Fe 52	8.25-9.96	0.563	25
COL68	6418677418525	Fe 68	9.96-11.56	0.77	25



COL25



COL52

Insulated stay wire sets SHS

An insulated set for medium voltage lines. The wire gauge is 25 mm² steel wire and the permitted load is up to 17.5 kN. All steel parts are hot-dip galvanized and plastic marking tubes are of weather and UV-resistant material.

Product code	GTIN	Description	Weight (kg)	Pack. /pcs
SHS25K.165L	6418677407697	Upper end clamp, ceramic, length 16.5 m	9.6	1
SHS25K.165R	6418677407703	Upper end iron, ceramic, length 16.5 m	10.7	1
SHS12.0611232	6418677402531	Upper end clamp, composite, L=18 m	11.2	1



Wire markers SP43

Wire markers are used for marking overhead lines and wires. They can be used at crossing of water courses and roadways, bird migration routes and near airports. It also prevents conductors from clashing together. The installation is easy with any standard operating rod, like CT48.64. Wire markers SP43 have a diameter of 200 mm.

Product code	GTIN	Cable diameter mm	Colour	Diameter mm	Weight (kg)	Pack. /pcs
SP43	6418677405303	Al/Fe 7-21	orange	200	0.4	10
SP43.1	6418677408205	Al/Fe 7-21	orange + reflectors	200	0.45	10
SP43.2	6418677408212	Cu 7-21	orange	200	0.45	10
SP43.3	6418677408229	Al/Fe 7-21	orange-white	200	0.45	10

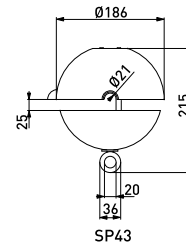

SP43



SP43.1



SP43.3

Warning balls SP48

The aviation warning ball SP48 is a visual eye catcher in the overhead line span.

Product code	GTIN	Cable diameter mm	Colour	Diameter mm	Weight (kg)	Pack. /pcs
SP48.1	6418677405341	Al/Fe 9-20	red/white	600	6.1	1
SP48.2	6418677413667	Al/Fe 9-20	white	600	6.1	1
SP48.3	6418677413674	Al/Fe 9-20	red	600	6.1	1

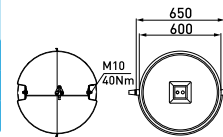

SP48.1



Suspension clamp SO86 with PK rubber inserts

Used for universal cables at straight line and angle poles. The rubber inserts PK143.12 or PK143.24 must be ordered separately for various cables. The suspension clamp is used in angles, one up to 30° and two up to 60°. With a construction of two suspension clamps a yoke SOT73 is needed.

Product code	GTIN	Nominal voltage (Un) kV	Tightening torque Nm	Weight (kg)	Pack. /pcs
SO86	6418677405143	12-24	15	0.908	10
PK143.12	6418677400803	12		0.14	100
PK143.24	6418677400810	24		0.074	100

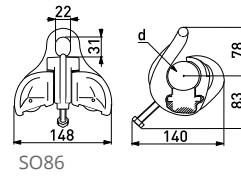

SO86

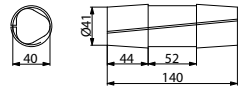

PK143.12



Suspension clamp SD21 with rubber inserts

Used for universal cables at straight line and angle poles. The rubber insert PK88 must be ordered separately. The suspension clamp is used in angles, one up to 30° and two up to 60°. With a construction of two suspension clamps a yoke SOT73 is needed.

Product code	GTIN	Nominal voltage (Un) kV	Tightening torque Nm	Weight (kg)	Pack. /pcs
SD21	6418677401527	12-24	10	2.24	1
PK88	6418677400988	12-24		1.1	10

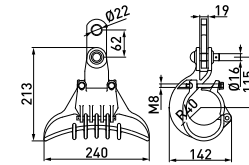

SD21

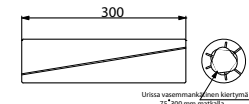

PK88



Suspension clamp SO150

Used in angle and suspension poles. Can also be used as a pulley when installing the cable. When the cable has been tightened to its final length, it is locked to the clamp. The clamp is used at angles max. 30 degrees depending on the bending radius and tightening strength of the cable.

Product code	GTIN	Nominal voltage (Un) kV	Tightening torque Nm	Weight (kg)	Pack. / pcs
SO150	6418677404443	12-24	25	2.2	4

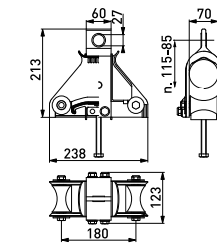

Suspension clamp SO241.1

For MV aerial bundled cables with bare messenger. Suitable for hook attachment. Breaking load is 22 kN.

Product code	GTIN	Messenger mm	Tightening torque Nm	Weight (kg)	Pack. /pcs
SO241.1	6418677419485	5.9-18.5	40	0.65	25

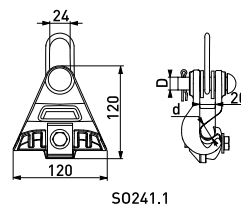

SO241.1

Suspension clamp SO214

Used for the suspension of overhead cables with uninsulated messenger in straight lines and angles up to 90°. Breaking load is 25 kN.

Product code	GTIN	Messenger mm	Tightening torque Nm	Weight (kg)	Pack. /pcs
SO214	6418677410666	4.8-13	48	0.248	50

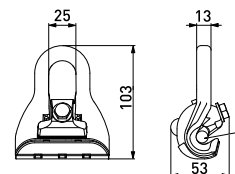

Suspension clamp SO69.95

The suspension clamp is used for the suspension of the insulated messenger in straight lines and at angles up to 90°. Breaking load is 22 kN.

Product code	GTIN	Messenger mm	Tightening torque Nm	Weight (kg)	Pack. /pcs
SO69.95	6418677414572	7-16.5	By hand	0.244	50

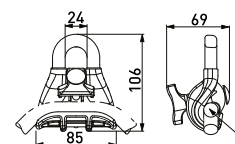

Suspension clamp SO220

Use for the suspension of the Axclight-H, Exclight-H cable with messenger in straight lines and at angles of up to 30° and as a double construction together with yoke SOT73 up to 60°. Breaking load is 22 kN.

Product code	GTIN	Messenger mm	Tightening torque Nm	Weight (kg)	Pack. /pcs
SO220	6418677414343	10.5-11.5	20	0.29	25

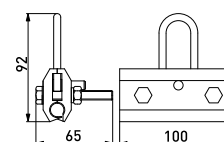

Yoke SOT73

Suspension console is used for universal cable suspension construction with two suspension clamps at line angles up to 60°. Suspension console is made of hot dip galvanized steel.

Product code	GTIN	Weight (kg)	Pack. /pcs
SOT73	6418677408922	7.2	1

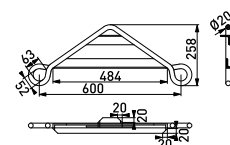



LOW



MEDIUM



Ensto has a wide range of tools for network building to facilitate the installation work.

The range includes e. g. ratchet, torque and fork wrenches, wedges, wire stringing wheels, pole climbing irons, dynamometers and swivel for wire linking. All our tools can be found in our Ensto Tools catalogue, www.ensto.com - Brochures.

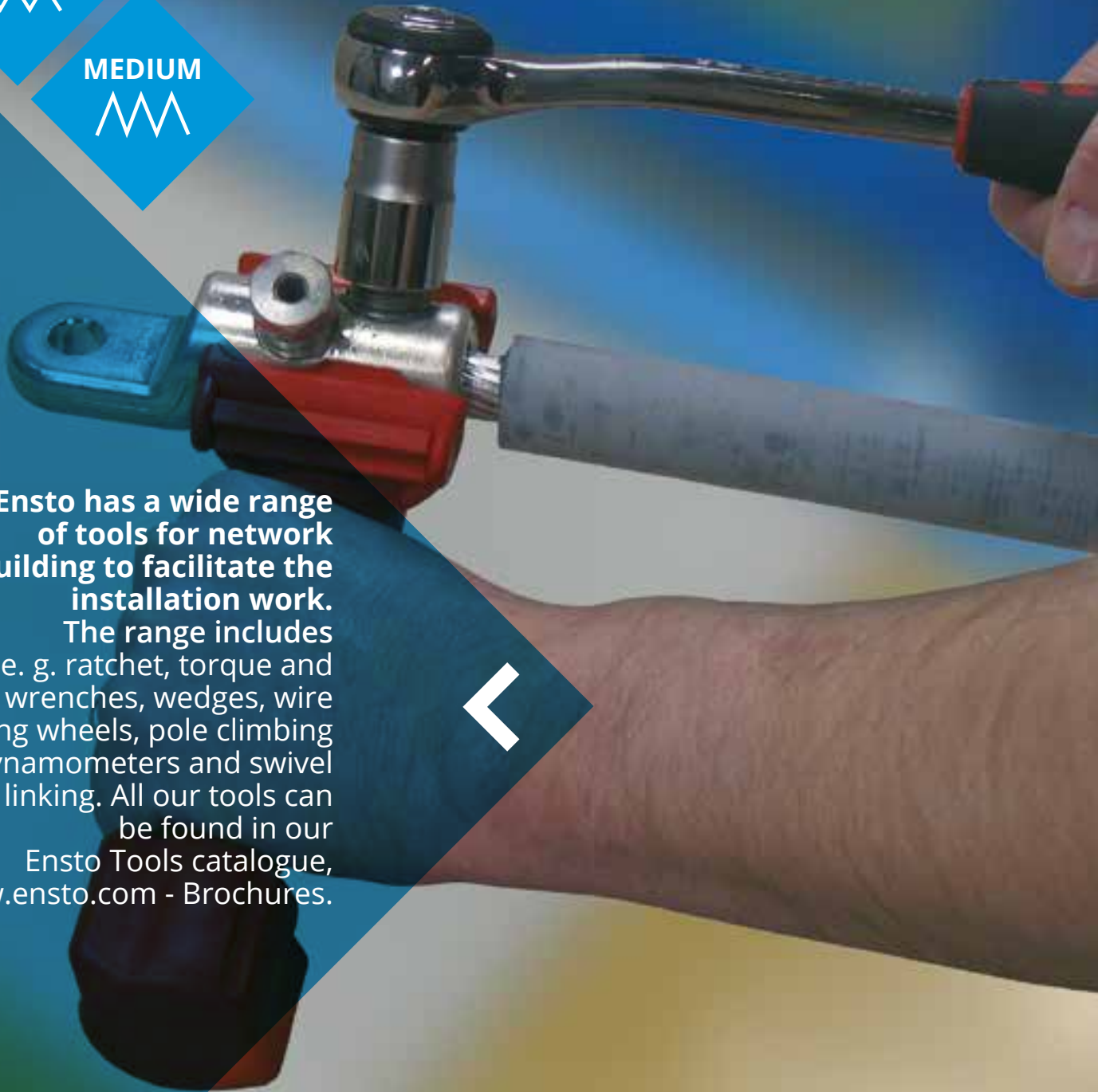

Tools

Wire brush ST18

In aluminium connections it is important to remove the Al-oxide from the aluminium surfaces by using a wire brush. Use of joint compound SR1 prevents further re-oxidation. ST18.2 is the case for ST18.

Product code	GTIN	Weight (kg)	Pack. /pcs
ST18	6418677405440	0.072	1
ST18.2	6418677405457	0.022	1

ST18



Joint compound SR1

Used for the prevention of oxidation on aluminium surfaces. The use of the wire brush and joint compound SR1 reduces the contact resistance. It also protects the connection from corrosion. There are no skin irritating ingredients in the grease.

Product code	GTIN	Weight (kg)	Pack. /pcs
SR1	6418677405402	0.225	25



Ratchet wrench CT164

For installation of connectors and suspension fittings. The wrench body is made of steel and the grip of oil resistant rubber. The wrench is double-sided 13 and 17 mm.

Product code	GTIN	Weight (kg)	Pack. /pcs
CT164	6418677414213	0.254	20



Torque wrench ST30

For tightening connectors and fittings with standard sockets. With aluminium connectors, it is essential that the bolts are tightened by using the correct torque. ST30 is a high quality adjustable wrench with a wide torque range. The read-outs are given in Nm and lbs.-ft. Socket adaptor mount 1/2". Tightening torque is 8-54 Nm.

Product code	GTIN	Weight (kg)	Pack. /pcs
ST30	6418677408755	0.89	10



Pulling grip CT103

Pulling grips are made of high-grade galvanized steel wire, in a double weave construction for safe and secure cable pulling. Grip length 600 mm.

Product code	GTIN	Diameter mm	SMFL kN	Weight (kg)	Pack. /pcs
CT103.35	6418677412073	20-30	22	0.232	1
CT103.50	6418677412080	30-40	36	0.303	1
CT103.95	6418677412097	40-50	54	0.586	1



Dynamometer ST112

Used for setting the correct tension on all kinds of overhead line conductors. The dynamometers are lightweight and compact. They have a built-in measuring dial with scales according to the maximum load.

Product code	GTIN	Maximum load kg	Step (kg)	Weight (kg)	Pack. /pcs
ST112.1	6418677414152	1000	20	1.179	1
ST112.2	6418677414169	2000	50	1.2	1
ST112.3	6418677414176	3000	50	2.3	1

CT103.35



Cable hoist ST116

Ratchet puller for line tensioning.

Product code	GTIN	Lift height m, single/double wire	Capacity kg, Single/double wire	Weight (kg)	Pack. /pcs
ST116	6418677414183	3/1.5	750/1500	4.1	1



Swivel for conductor linking CT104

Swivels are essential for effective pulling operation of underground cables and overhead conductors. The swivels are fitted with bearings to prevent build up of twist and loops in the cable or pulling rope. Rope dia. 10 mm, working tension 10 kN.

Product code	GTIN	Weight (kg)	Pack. /pcs
CT104	6418677412103	0.45	20



Sockets for torque wrench ST30: ST12, ST13 and ST115

Product code	GTIN	Socket size (mm), form	Weight (kg)	Pack. /pcs
ST12	6418677411557	17 mm, hexagonal	0.066	20
ST13	6418677411564	13 mm, hexagonal	0.056	20
ST115	6418677414138	19 mm, hexagonal	0.075	20



ST12

Fork wrench ST34

The ST34 is for holding the connector while tightening the bolts. Approved also for insulation piercing connectors with live conductors.

Product code	GTIN	Weight (kg)	Pack. /pcs
ST34	6418677405549	0.337	25



Wedges ST31 and ST192

During the installation of connectors the phase conductors of an insulated overhead cable can be separated by using wedges. The wedge can also be used when installing suspension clamps.

Product code	GTIN	Description	Weight (kg)	Pack. /pcs
ST31	6418677405518	Two plastic wedges	0.109	10
ST192	6418677408588	Plastic wedge for LV ABC	0.14	10



ST31

Wedges PMR87 and PM154

During the installation of connectors, the phase conductors of an insulated overhead cable can be separated by using wedges. These wedges can be left on the cable even after the installation.

Product code	GTIN	Description	Weight (kg)	Pack. /pcs
PMR87	6418677408830	4x95 mm ² , plastic	0.022	250
PM154	6418677408816	4x50 mm ² , plastic	0.017	500

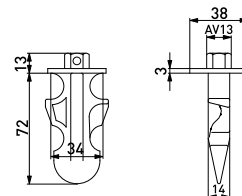

PMR87

Wire stringing wheels ST26.1, ST26.11, ST26.22 and ST26.33

Used for pulling in overhead cables. ST26.1, ST26.33 and ST26.11 are used for straight lines and small angles up to 30 degrees. Double pulley ST26.22 is used for larger angles up to 90 degrees.

Product code	GTIN	Description	Weight (kg)	Pack. /pcs
ST26.1	6418677408625	Cable groove 50 mm, nylon	1.458	10
ST26.11	6418677410116	Cable groove 50 mm, nylon, with chain attachment	3.9	1
ST26.22	6418677410123	Cable groove diameter 50 mm, nylon with chain attachment, double pulley	6.25	1
ST26.33	6418677410130	Cable groove 77 mm, aluminium	2.172	5

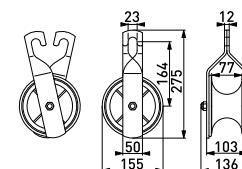

ST26.33



Tightening tool CT42

CT42 is a special tool which is used for tightening the steel band COT37.

Product code	GTIN	Weight (kg)	Pack./pcs
CT42	6418677412332	1.95	1



Pole climbing irons CT2

Made of Al-alloy. The irons can be adjusted with different sizes of wooden poles.

Product code	GTIN	Pole diam. mm	Weight (kg)	Pack./pcs
CT2	6418677408786	140-300	4.2	1



Pole climbing irons ST155

Made of alloyed and heat-refined steel. The welded and forged areas of the irons, are tested for cracks. Irons ST155 are supplied with straps.

Product code	GTIN	Pole diam. mm	Weight (kg)	Pack./pcs
ST155.8	6418677408304	Max. 200	2.6	5
ST155.11	6418677408281	Max. 280	2.7	5
ST155.14	6418677408298	Max. 350	2.8	5



ST155.8

Come along clamps ST102 for four core cables

For tensioning overhead line spans of four core cables. The grips cover a wide range of diameters and can apply high-tension force. ST102 uses an articulated construction. It is easy to mount and change on the line.

Product code	GTIN	Description	Weight (kg)	Pack./pcs
ST102.50	6418677430770	4x25-50 mm ²	2.3	1
ST102.95	6418677430787	4x70-95 mm ²	4.31	1
ST102.120	6418677430794	4x120 mm ²	4.3	1



ST102.50

Come along clamps CT102 and CT105

For tensioning both bare and covered conductors overhead line spans. The grips cover a wide range of diameters and make a good fixing and high tension force.

Product code	GTIN	Conductor diameter mm	Weight (kg)	Pack./pcs
CT102.501	6418677409196	7.87-13.46	1.7	1
CT102.1201	6418677409189	13.46-18.80	3.77	2
CT105.20	6418677416132	4-20	2.75	10
CT105.35	6418677416149	3-8	0.828	10
CT105.70	6418677416156	5-10	1.16	10



CT102.501



CT105.20



CT105.35





LENUSA (PT. LAUTAN ENERGI NUSANTARA)

Gedung 18 Office Park Fl. 22 Unit 22 E,F,G Jl.TB. Simatupang Kav. 18 Jakarta Selatan

M: 0811 1328 899 T: 021-8064 1978 F: 021-8064 1999 E: sales@lenusa.co.id - info@lenusa.co.id - pt.lenusa@gmail.com
www.lenusa.co.id